



GE Fanuc Automation

Computer Numerical Control Products

*α Series Servo Amplifier Module (SVM)
With FSSB*

Servo Setup Manual

GFK-1546

April 1998

Warnings, Cautions, and Notes as Used in this Publication

Warning

Warning notices are used in this publication to emphasize that hazardous voltages, currents, temperatures, or other conditions that could cause personal injury exist in this equipment or may be associated with its use.

In situations where inattention could cause either personal injury or damage to equipment, a Warning notice is used.

Caution

Caution notices are used where equipment might be damaged if care is not taken.

Note

Notes merely call attention to information that is especially significant to understanding and operating the equipment.

This document is based on information available at the time of its publication. While efforts have been made to be accurate, the information contained herein does not purport to cover all details or variations in hardware or software, nor to provide for every possible contingency in connection with installation, operation, or maintenance. Features may be described herein which are not present in all hardware and software systems. GE Fanuc Automation assumes no obligation of notice to holders of this document with respect to changes subsequently made.

GE Fanuc Automation makes no representation or warranty, expressed, implied, or statutory with respect to, and assumes no responsibility for the accuracy, completeness, sufficiency, or usefulness of the information contained herein. No warranties of merchantability or fitness for purpose shall apply.

PowerMotion is a trademark of GE Fanuc Automation North America, Inc.

Chapter 1	Descriptions.....	1-1
Chapter 2	FSSB Setting Screens.....	2-1
	Displaying the FSSB Setting Screens.....	2-1
	Amplifier Setting Screen	2-2
	Axis Setting Screen.....	2-4
	Amplifier Maintenance Screen.....	2-5
	Settings.....	2-7
Chapter 3	Setting Parameters.....	3-1
	Setting Parameters	3-1
	Slave	3-2
	Default Setting.....	3-3
	Automatic Setting	3-5
	Examples.....	3-7
	Manual Setting.....	3-17
Chapter 4	Description of Parameters	4-1
	Parameter No. 1902	4-1
	Parameter No. 1904	4-2
	Parameter No. 1905	4-3
	Parameter No. 1910 – 1919.....	4-5
	Parameter No. 1920 – 1929.....	4-8
	Parameter No. 1931 – 1932.....	4-9
	Parameter No. 1933	4-10
	Parameter No. 1934.....	4-11
	Parameter No. 1936 – 1937.....	4-12
Chapter 5	Troubleshooting	5-1
	Pulse Coder	5-1
	Servo Amplifier	5-2
	P/S Alarm.....	5-3
	Frequently Asked Setup Questions.....	5-4
Appendix A	Separate Type Detector Interface Unit	A-1

Chapter

1

Descriptions

Chapter 1 contains B-65162E/02-25, *Alpha Series Servo Amplifier Module (SVM) with FSSB Supplemental Descriptions Manual*.

This page intentionally left blank.

FANUC SERVO AMPLIFIER α series
 SERVO AMPLIFIER MODULE (SVM) with FSSB
 DESCRIPTIONS

				TITLE	SERVO AMPLIFIER MODULE WITH FSSB DESCRIPTIONS
01	97.07.11	堀越	FIRST EDITION	DRAW. No. <i>S. Makubara</i>	B-65162E/02-25
EDIT.	DATE	DESIG.	DESCRIPTION	FANUC LTD	SHEET 001 / 10

Table of contents

1. GENERAL	• • • 003
2. SPECIFICATIONS	• • • 003
2.1 DESIGNATIONS	• • • 003
2.2 SPECIFICATIONS	• • • 004
2.2.1 CONNECTION FOR OPTICAL CABLE OF FSSB	• • • 004
2.2.2 OVERALL CONNECTION DIAGRAM	• • • 005
2.2.3 DETAILED CONNECTOR	• • • 007
2.2.4 ALARM	• • • 010
2.2.5 STANDARD	• • • 010
3. OTHERS	• • • 010
3.1 ORDERING LIST	• • • 010

				TITLE	SERVO AMPLIFIER MODULE WITH FSSB DESCRIPTIONS	
				DRAW. No.	B-65162E/02-25	
EDIT.	DATE	DESIG.	DESCRIPTION	FANUC LTD	SHEET	002/10

2.2 SPECIFICATIONS

The differences between SVM with FSSB and the current SVM are shown below.
 As for the other specifications,
refer to FANUC CONTROL MOTOR AMPLIFIER α series DESCRIPTIONS (B-65162E/02).

2.2.1 CONNECTION OF OPTICAL CABLE

- Connect the optical cable from COP10A on CNC to COP10B on the first AMP.
- The optical cables from COP10A of the previous AMP is connected to COP10B of the next AMP.
- Please put the attached cap on COP10A of the last AMP to protect the optical connector form dust.
- Up to 8 axes are available. (The number of the axes is not the number of the AMPs.)

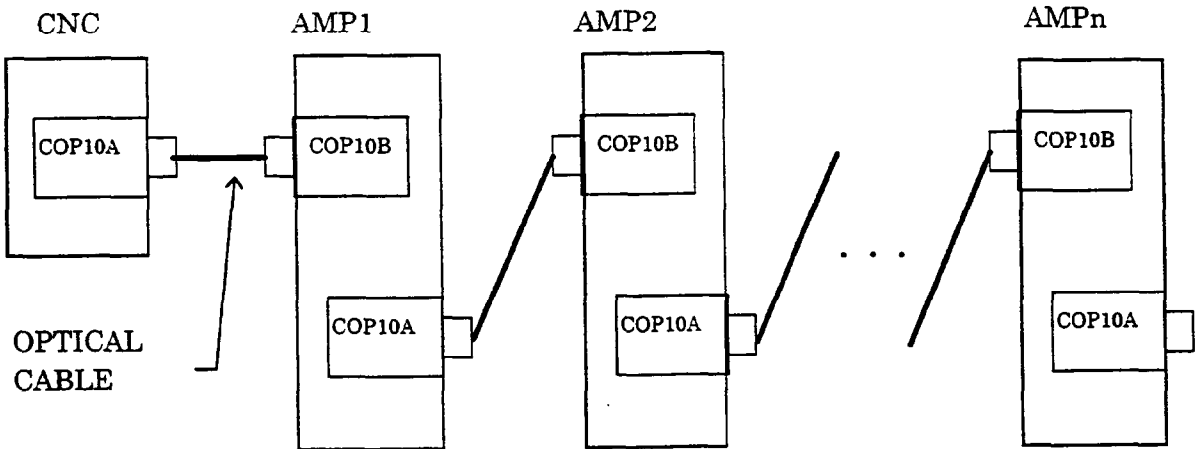
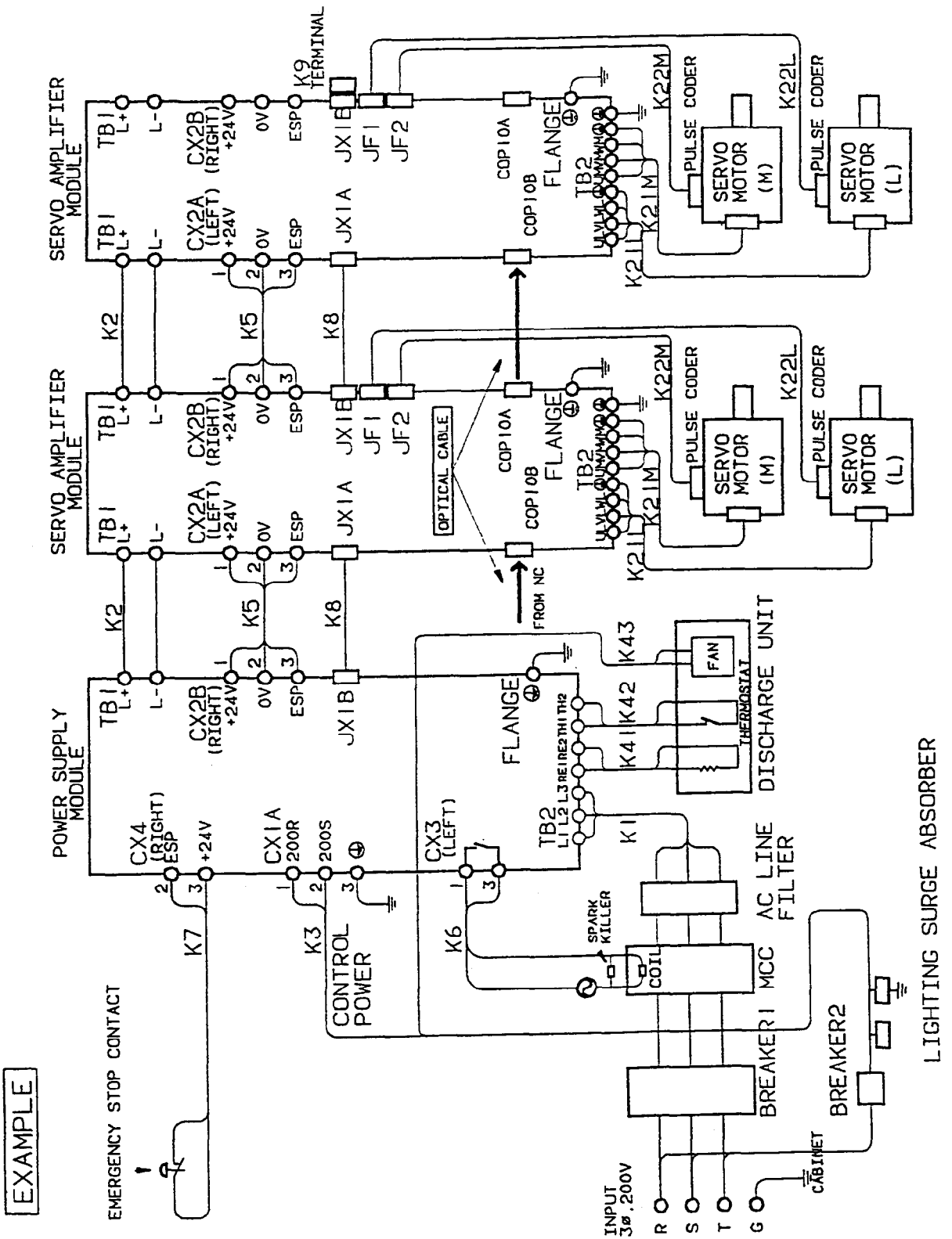

Fig.1 CONNECTION OF OPTICAL CABLE

				TITLE	SERVO AMPLIFIER MODULE WITH FSSB DESCRIPTIONS	
				DRAW. No.	B-65162E/02-25	
EDIT.	DATE	DESIG.	DESCRIPTION	FANUC LTD	SHEET	004 /10

2.2.2 OVERALL CONNECTION DIAGRAM

(a) Except for SVM1-240, 360



EXAMPLE

				TITLE	SERVO AMPLIFIER MODULE WITH FSSB DESCRIPTIONS	
				DRAW. No.	B-65162E/02-25	
EDIT.	DATE	DESIG.	DESCRIPTION	FANUC LTD	SHEET	005 / 10

EXAMPLE

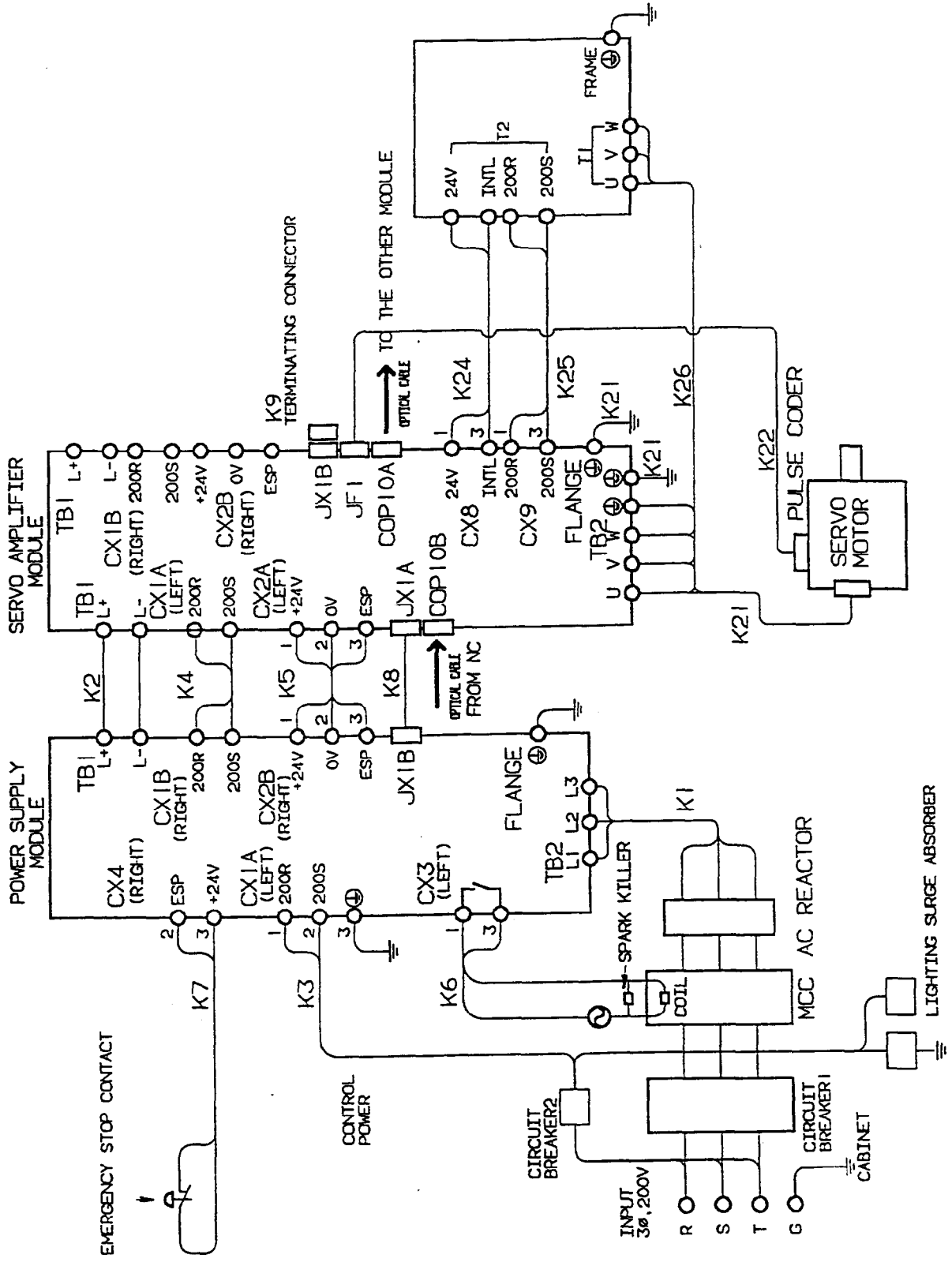

EDIT.	DATE	DESIG.	DESCRIPTION	FANUC LTD	SHEET	006 /10
				TITLE	SERVO AMPLIFIER MODULE WITH FSSB DESCRIPTIONS	
				DRAW. No.	B-65162E/02-25	

2.2.3 DETAILED CONNECTION

(a) 1 AXIS and 2 AXES SVM

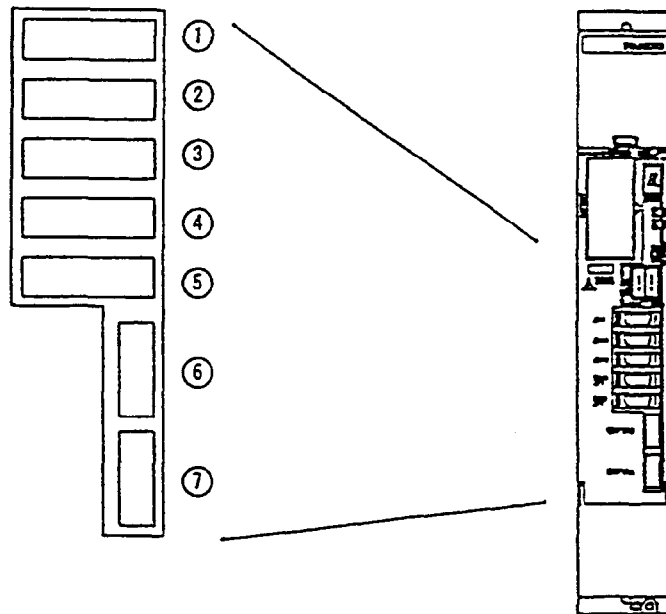

Tab. 2 Connectors

No.	Name	Indication
①	Signal check connector	JX5
②	Input connector for interface between modules	JX1A
③	Output connector for interface between modules	JX1B
④	Pulse coder connector:L-axis	JF1
⑤	Pulse coder connector:M-axis	JF2
⑥	Input connector for FSSB interface	COP10B
⑦	Output connector for FSSB interface	COP10A

				TITLE	SERVO AMPLIFIER MODULE WITH FSSB DESCRIPTIONS
				DRAW. No.	B-65162E/02-25
EDIT.	DATE	DESIG.	DESCRIPTION	FANUC LTD	SHEET 007 /10

(b) 3 AXES SVM

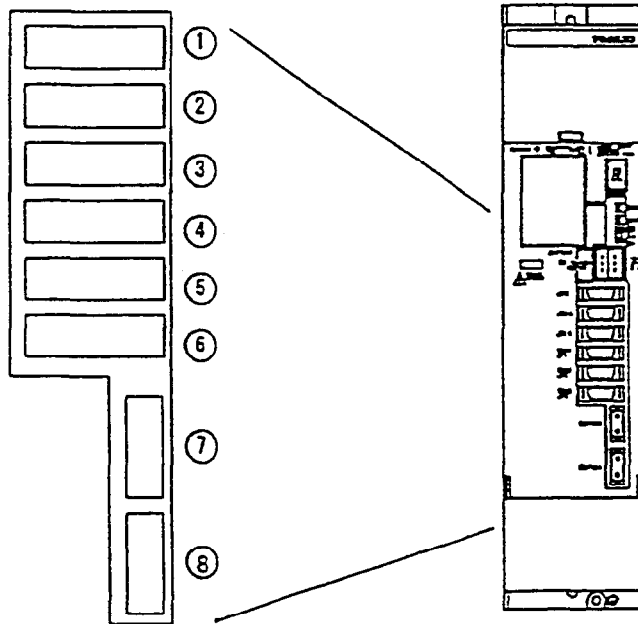

Tab. 3 Connectors

No.	Name	Indication
①	Signal check connector	JX5
②	Input connector for interface between modules	JX1A
③	Output connector for interface between modules	JX1B
④	Pulse coder connector:L-axis	JF1
⑤	Pulse coder connector:M-axis	JF2
⑥	Pulse coder connector:N-axis	JF3
⑦	Input connector for FSSB interface	COP10B
⑧	Output connector for FSSB interface	COP10A

				TITLE	SERVO AMPLIFIER MODULE WITH FSSB DESCRIPTIONS
				DRAW. No.	B-65162E/02-25
EDIT	DATE	DESIG.	DESCRIPTION	FANUC LTD	SHEET 008 / 10

(c) SVM1-240,360

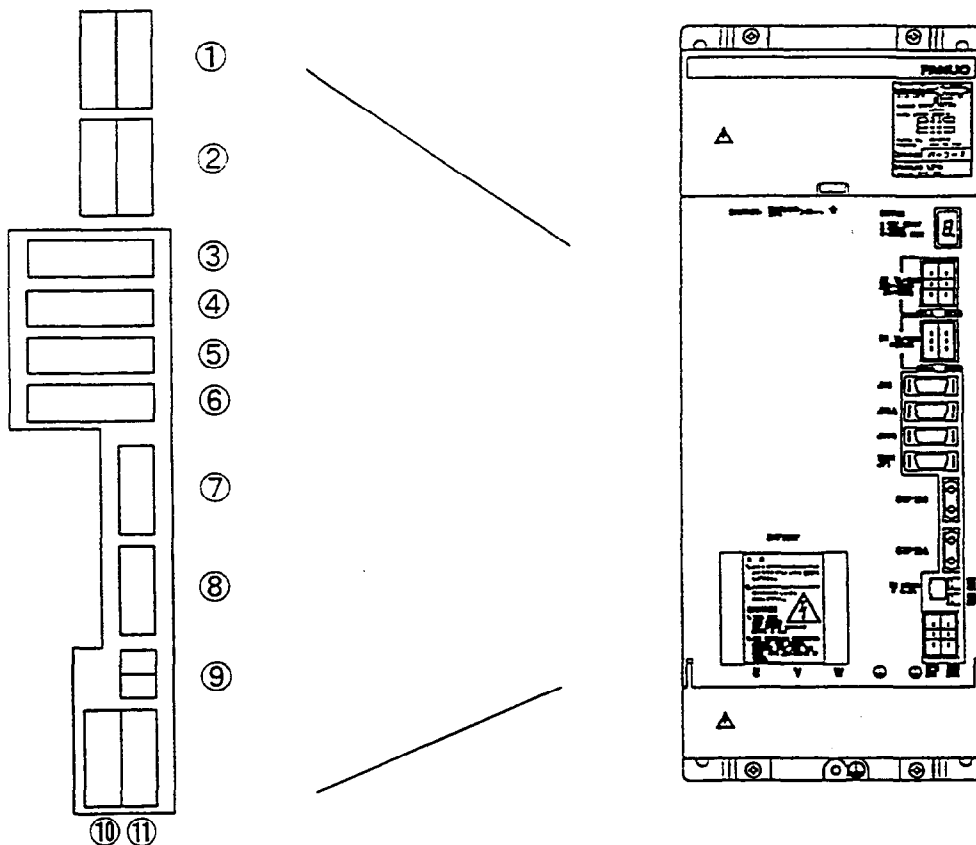

Tab.4 Connectors

No.	Name	Indication
①	Input/Output connector for AC200V power supply	CX1A, CX1B
②	Input/Output connector for DC24V power supply	CX2A, CX2B
③	Signal check connector	JX5
④	Input connector for interface between modules	JX1A
⑤	Output connector for interface between modules	JX1B
⑥	Pulse coder connector	JF1
⑦	Input connector for FSSB interface	COP10B
⑧	Output connector for FSSB interface	COP10A
⑨	Power connector for ABS pulse coder battery	CX5X, CX5Y
⑩	Connector for Dynamic Brake interface	CX8
⑪	Connector for coil of Dynamic Brake	CX9

				TITLE	SERVO AMPLIFIER MODULE WITH FSSB DESCRIPTIONS
				DRAW. No.	B-65162E/02-25
EDIT.	DATE	DESIG.	DESCRIPTION	FANUC LTD	SHEET 009 /10

2.2.4 ALARM

Alarms in the table below are added to the current SVM.
Those alarms are related with FSSB.

Type	Description	LED (Note 1)
FSSB disconnection (Type 1)	The disconnection of COP10A side. (See Fig.2) (There is the failure in the connector or the optical cable.)	L
FSSB disconnection (Type 2)	The disconnection of COP10B side. (See Fig.2) (There is the failure in the connector or the optical cable.)	U

(Note 1)

The detected alarm conditions are indicated by the 7-segment LED on the front of the SVM.

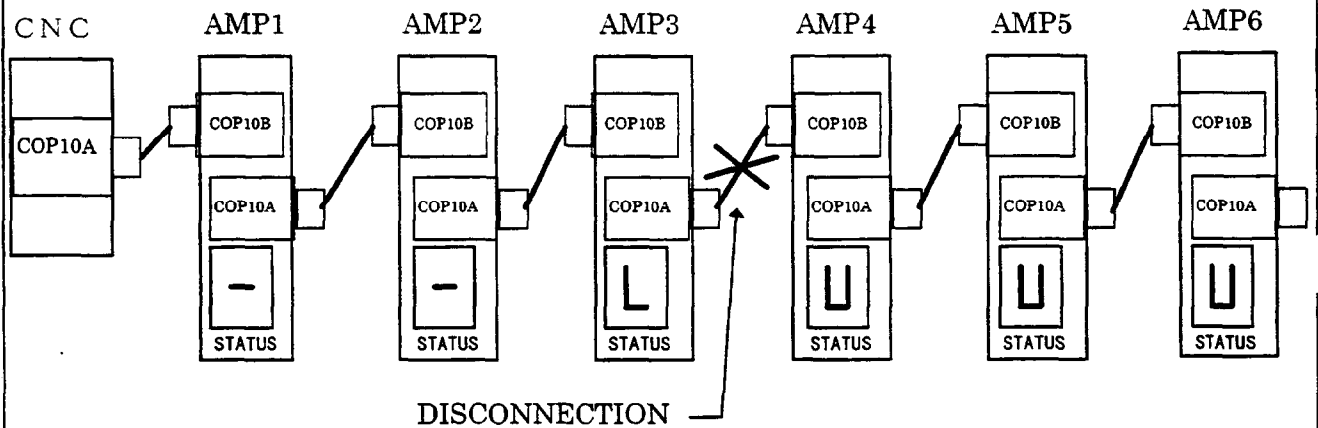

Fig. 2 FSSB disconnection

2.2.5 STANDARD

SVM with FSSB has been designed to comply with VDE0160.

3. OTHERS

3.1 ORDERING LIST

The ordering list for SVM with FSSB is included in "Order list for FANUC Servo amplifier α series (6th edition : B-65161EN/07).

				TITLE	SERVO AMPLIFIER MODULE WITH FSSB DESCRIPTIONS	
				DRAW. No.	B-65162E/02-25	
EDIT.	DATE	DESIG.	DESCRIPTION	FANUC LTD	SHEET	010/10

Chapter 2

FSSB Setting Screens

Information pertaining to the amplifiers and axes connected to the CNC through Serial Servo Bus (FSSB) optical cables are set on the FSSB Setting screens.

There are three FSSB Setting screens:

- Amplifier Setting screen.
- Axis Setting screen.
- Amplifier Maintenance screen.

Displaying the FSSB Setting Screens

To display the FSSB Setting screens, press the <SYSTEM> function key, the most right soft key, several times and the [FSSB] soft key.

When the [FSSB] soft key is pressed, the Amplifier Setting screen, or one of the previously selected FSSB Setting screens, is displayed with the following soft keys.

[AMP]	[AXIS]	[MAINTE]	[]	[]
---------	----------	----------	-----	-----

Press the [AMP] soft key to display the Amplifier Setting screen.

Press the [AXIS] soft key to display the Axis Setting screen.

Press the [MAINTE] soft key to display the Amplifier Maintenance screen.

Amplifier Setting Screen

Information on each slave (amplifier or pulse module) is displayed on the Amplifier Setting screen.

AMPLIFIER SETTING					01000	N00001
NO.	AMP	SERIES	UNIT	CUR.	[AXIS]	NAME
1	A1-L	α	SVM-HV	40AL	[1]	X
2	A1-M	α	SVM	12A	2	Y
3	A2-L	β	SVU	20A	3	Z
4	A3-L	α	SVM	20A	4	A
5	A3-M	α	SVM	40A	5	B
7	A4-L	α	SVM	240A	6	C
NO.	EXTRA	TYPE	PCB	ID		
6	M1	A	0000	DETECTOR(4AXES)		
8	M2	B	12AB	DETECTOR(4AXES)		
>						
MDI	****	***	***		13:11:56	
[AMP]		[AXIS]		[MAINTE]	[]	[(OPRT)]

The following information is displayed on the Amplifier Setting screen:

Table 2 - 1. Amplifier Setting Screen Information

Item	Name	Description
NO.	Slave Number	Each slave is assigned a number from 1 to 10 , according to its distance from the CNC.
AMP	Amplifier Type	The amplifier type consists of the letter A for Amplifier plus a number which shows its order in the list of amplifiers and an alphabetic character representing the axis number in the amplifier (L for the first axis, or M for the second axis). For example: A2-L : the first axis of the second amplifier.
AXIS	Axis Number	The axis number set in parameters (No. 1920 - 1929) is displayed. If the value set in the parameter is out of range (from 1 to the maximum number of controlled axes), a 0 is displayed.
NAME	Axis Name	The axis name (parameter No. 1020) is displayed.
<i>Amplifier Information</i>		
UNIT	Unit	Kind of Servo Amplifier Unit.
SERIES	Series	Servo Amplifier Series.
CUR.	Current	Maximum current.
<i>Pulse Module Information</i>		
EXTRA	Order	The letter M for Pulse Module plus a number which shows its order in the list of pulse modules
TYPE	Pulse Module Type	An alphabetic character representing the pulse module type is displayed.
PCB ID	Pulse Module ID	The pulse module ID is displayed in hexadecimal. If the pulse module is supplied for 4 axes, "DETECTOR(4AXES)" is also displayed. If two pulse modules are supplied for 8 axes, "DETECTOR(8AXES)" is displayed.

The following information is displayed on the Amplifier Maintenance screens:

Table 2 - 3. Amplifier Maintenance Screens Information

Item	Name	Description
AXIS	Axis Number	Axis number.
NAME	Axis Name	Axis name.
AMP	Amplifier Type	Type of amplifier connected to each axis.
SERIES	Series	Series of amplifier connected to each axis.
UNIT	Unit Kind of Amplifier	Unit kind of amplifier connected to each axis.
AXES	Axes	Maximum number of axes of the amplifier connected to each axis.
CUR.	Maximum Current	The maximum current of the amplifier connected to each axis.
EDITION	Unit Edition	Unit edition of the amplifier connected to each axis.
TEST	Test Date	Test date of the amplifier connected to each axis. For example: 961127 : November 27, 1996
MAINTE NO.	Maintenance Number	Maintenance number of the amplifier connected to each axis.

Settings

When the **[OPRT]** soft key is pressed on the Amplifier Setting or Axis Setting screen, the following soft keys are displayed:

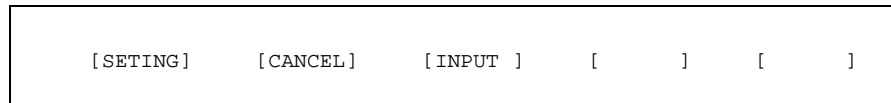

To set the parameters, move the cursor to each item in MDI mode or Emergency Stop condition, enter a number, and press the **[INPUT]** soft key (<INPUT> key on the MDI panel).

Then, press the **[SETTING]** soft key. If a warning occurs, the values are incorrect and must be corrected.

To display the values set in the parameters, press the **[CANCEL]** soft key.

When the CNC is powered ON, the values set in the parameters are displayed.

Note

Do not set the values for the parameters by MDI input or G10 input. The values for these parameters can only be set on the FSSB Setting screens.

If a warning occurs when the **[SETTING]** soft key is pressed, enter the correct value or press the **[CANCEL]** soft key to stop the warning. Pressing the <RESET> key will not release the warning.

Amplifier Setting Screen

The following item can be set on the Amplifier Setting screen:

Item	Name	Description
AXIS	Axis Number	<p>Enter the axis number from 1 to the maximum number of controlled axes.</p> <p>If a value that is out of the data range is entered, the warning "FORMAT ERROR" occurs.</p> <p>When the [SETTING] soft key is pressed, if 0 or overlapped numbers are set, the warning "DATA IS OUT OF RANGE" occurs, and input numbers are not set in their parameters.</p>

Axis Setting Screen

The following item can be set on the Amplifier Setting screen:

Item	Name	Description
M1	Connector Number of the 1st Pulse Module	Enter the connector number for the axis using the first pulse module. The data range is from 1 to the maximum number of the first pulse module connector. 0 is set for the axis not using the first pulse module. If the input value is out of range, the warning "FORMAT ERROR" occurs.
M2	Connector Number for the 2nd Pulse Module	Enter the connector number for the axis using the second pulse module. The data range is from 1 to the maximum number of the second pulse module connector. 0 is set for the axis not using the second pulse module. If the input value is out of range, the warning "FORMAT ERROR" occurs.
1-DSP	1-DSP Axis	Enter 1 for the Cs contouring control axis. If a value other than 0 or 1 is entered, the warning "FORMAT ERROR" occurs.
CS	Cs Contour Control Axis	Enter 1 for the Cs contouring control axis. If a value other than 0 or 1 is entered, the warning "FORMAT ERROR" occurs.
TNDM	Tandem Control Axis	When tandem control is used, enter two consecutive numbers, one odd for a master and one even for a slave. The data range is from 1 to 8 . If a value that is out of range is entered, the warning "FORMAT ERROR" occurs.

Chapter 3

Setting Parameters

The FANUC Serial Servo Bus (FSSB) system requires you to set the following parameters:

- Parameter No. 1023.
- Parameter No. 1905.
- Parameter No. 1910 – No. 1919.
- Parameter No. 1936 and 1937.

Setting Parameters

There are three ways to set these parameters:

1. Default setting.
2. Automatic setting.
3. Manual setting.

Note

Because of the limitations with the Default setting, it is recommended that you use either the Automatic or Manual setting.

Default Setting

Setting the parameter in No. 1023 enables the default settings for the remaining parameters. You do not need to set parameter No. 1905, 1910 – 1919, 1936, or 1937. However, the functions, which you can then use, are limited.

Automatic Setting

By using the FSSB Setting screen to enter the amplifier and axis information, the CNC automatically calculates the values of parameters No. 1905, 1910 –1919, 1936, and 1937, and sets these values in the parameters.

Manual Setting

Parameter No. 1905, 1910 – 1919, 1936, and 1937 can also be set manually. However, before you attempt to set these parameters manually, you must have a thorough understanding of the parameters.

Slave

In the FSSB system, the servo amplifier and pulse module are connected to the CNC by an optical cable. The servo amplifier and pulse module are referred to as *slaves*. A 2-axis amplifier consists of two slaves, while a 3-axis amplifier consists of three slaves. Each slave is assigned a slave number from 1 to 10, according to its distance from the CNC.

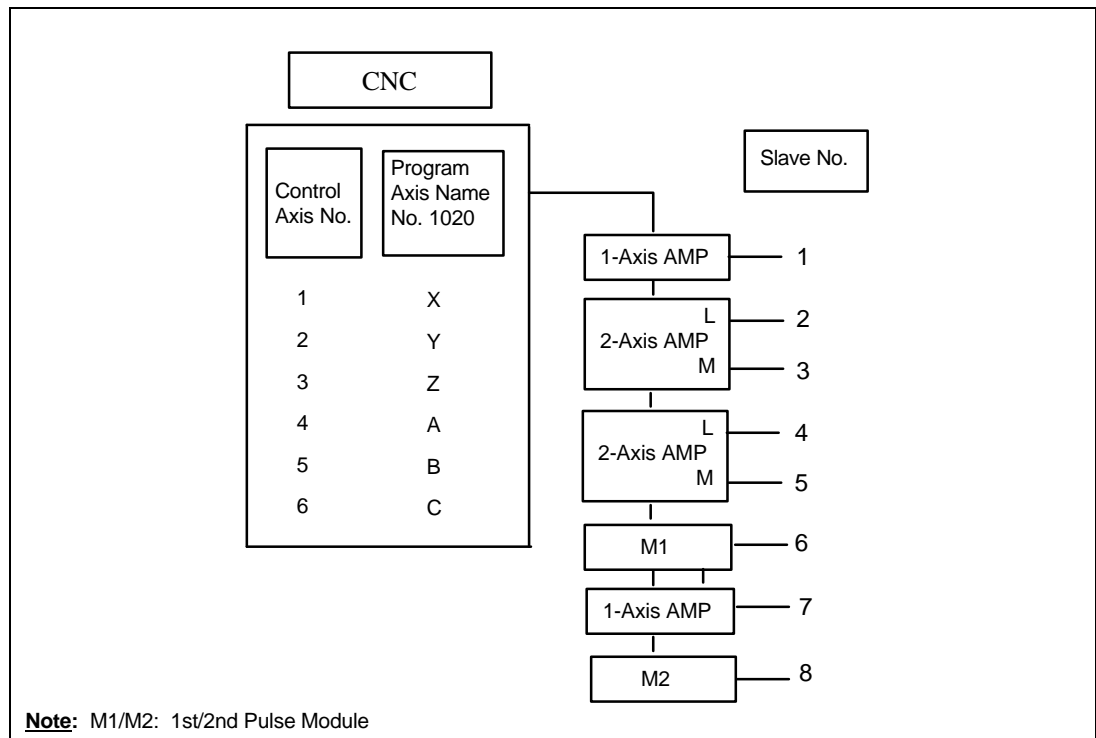

Default Setting

When the following parameters are set, the Default setting is in effect:

- No. 1902#0 = 0
- No. 1902#1 = 0
- No. 1910 to 1919 = 0 (all parameters are 0)

In the Default setting, the value of parameter No. 1023 is set as the slave number. For example, an axis whose value of parameter No. 1023 is 1 is connected with the nearest amplifier to the CNC, and an axis whose parameter value is 2 is connected with the next amplifier.

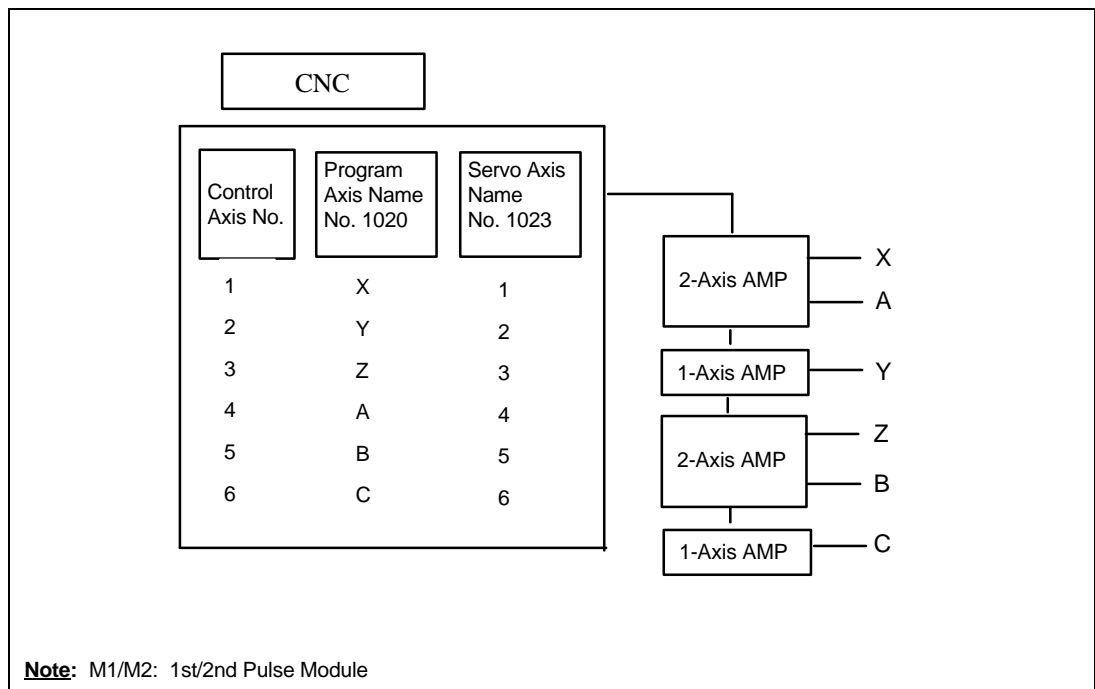

The following functions and settings cannot be used in the Default setting:

- The separate detector interface cannot be used.
- Values which are not consecutive cannot be set in parameter No. 1023. For example, the following setting is not allowed because 2 does not exist.

Axis	No. 1023
X	1
Y	3
Z	4

- The following servo functions are not allowed:
 - Learning control.
 - 125 μ s current loop.
 - High speed interface.
 - Simple electrical gear box (EGB).

Automatic Setting

Under the following conditions, you can use the FSSB Setting screen to set the parameters automatically:

No. 1902#0=0

No. 1902#1=0

To set the parameters automatically using the FSSB Setting screen, follow this procedure:

1. Set servo axis No. 1023. Then, set the number of the axis to No. 1023 to correspond to the total number of amplifier axes.
2. Initialize the servo parameters on the Servo Initial Setting screen.
3. Turn power to the CNC OFF and then ON.
4. Press the **SYSTEM** function key.
5. Press the ▶ key several times to display the **[FSSB]** soft key. Then, press the **[FSSB]** soft key to display the Amplifier Setting screen.

AMPLIFIER SETTING						
NO.	AMP	SERIES	UNIT	CUR.	[AXIS]	NAME
1	A1-L	α	SVM	40AL	[1]	X
2	A1-M	α	SVM	12A	[2]	Y
3	A2-L	β	SVU	20A	[3]	Z
4	A3-L	α	SVM	40A	[4]	A
5	A3-M	α	SVM	80A	[5]	B
7	A4-L	α	SVM	40AS	[6]	C
NO.	EXTRA	PCB	ID			
6	M1	A	0008 DETECTOR(4AXES)			
8	M2	A	0008 DETECTOR(4AXES)			
>						
MDI	****	***	***	13:11:56		
	[AMP]	[AXIS]	[MAINT]	[]	[(OPRT)]	

6. Enter the axis name for each amplifier on the Amplifier Setting screen.

Note

Do not set the control axis name to 0 or a duplicated value.

Examples

Semi-Closed Loop Example

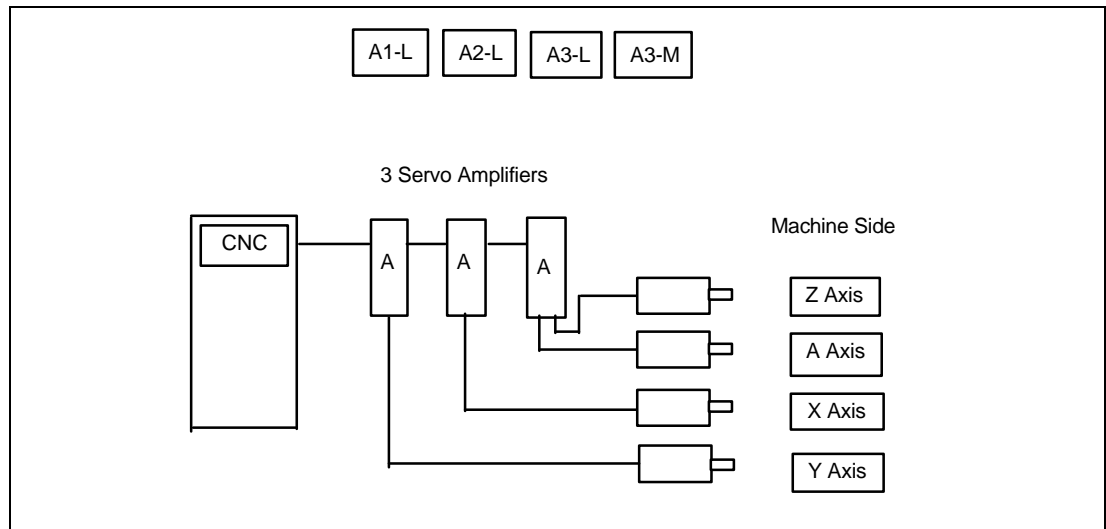

1. Set parameter No. 1023 as follows:
X : 1
Y : 2
Z : 3
A : 4
2. Set the servo initial setting for each axis.
3. Turn power to the CNC OFF and then ON.

4. Enter the axis number on the Amplifier Setting screen.

AMPLIFIER SETTING						
NO.	AMP	SERIES	UNIT	CUR.	[AXIS]	NAME
1	A1-L	α	SVM	40A	[2]	Y
2	A2-L	α	SVM	40A	[1]	X
3	A3-L	α	SVM	40A	[4]	A
4	A3-M	α	SVM	80A	[3]	Z
NO.	EXTRA	TYPE	PCB	ID		
>						
MDI	****	***	***		13:11:56	
[AMP]		[AXIS]	[MAINTE]	[]	[(OPRT)]

5. Press the **[SETTING]** soft key.
6. Press the **SYSTEM** function key.
7. Press the  key several times to display the **[FSSB]** soft key. Then, press the **[FSSB]** soft key to change the Amplifier Setting screen.
8. Press the **[AXIS]** soft key, the **[(OPRT)]** soft key, and then the **[SETTING]** soft key. The setting will be complete after you turn the CNC OFF and then ON.

Fully Closed Loop Example

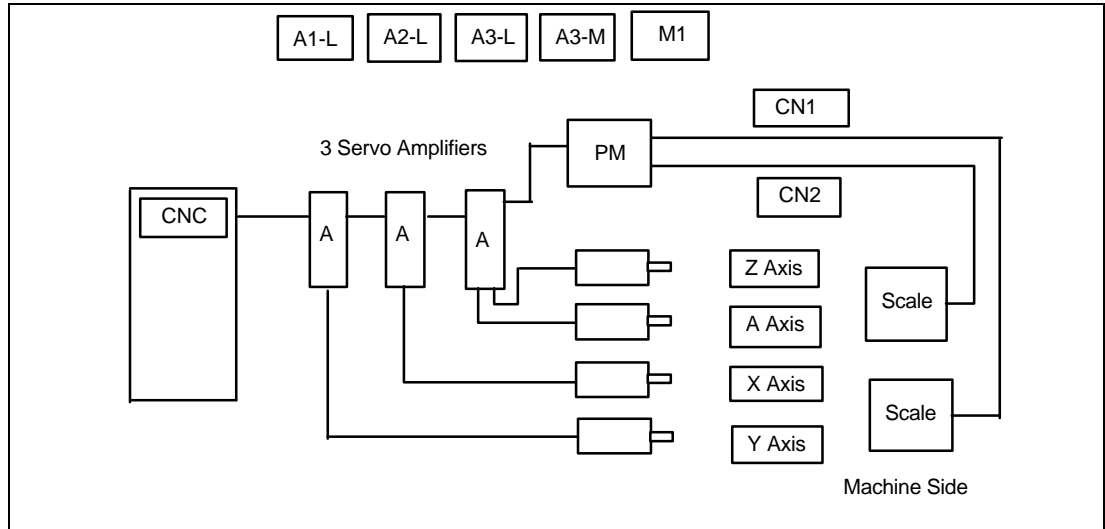

1. Set parameter No. 1023 as follows:
 - X : 1
 - Y : 2
 - Z : 3
 - A : 4
2. Set the servo initial setting for each axis.
3. Turn power to the CNC OFF and then ON.
4. Enter the axis number on the Amplifier Setting screen.

AMPLIFIER SETTING						
NO.	AMP	SERIES	UNIT	CUR.	[AXIS]	NAME
1	A1-L	α	SVM	40A	[2]	Y
2	A2-L	α	SVM	40A	[1]	X
3	A3-L	α	SVM	40A	[4]	A
4	A3-M	α	SVM	80A	[3]	Z
NO.	EXTRA	TYPE	PCB	ID		
5	M1	A	0008	DETECTOR(4AXES)		
>						
MDI	****	***	***	13:11:56		
[AMP]	[AXIS]	[MAINTN]	[]	[(OPRT)]		

Cs Axis Example

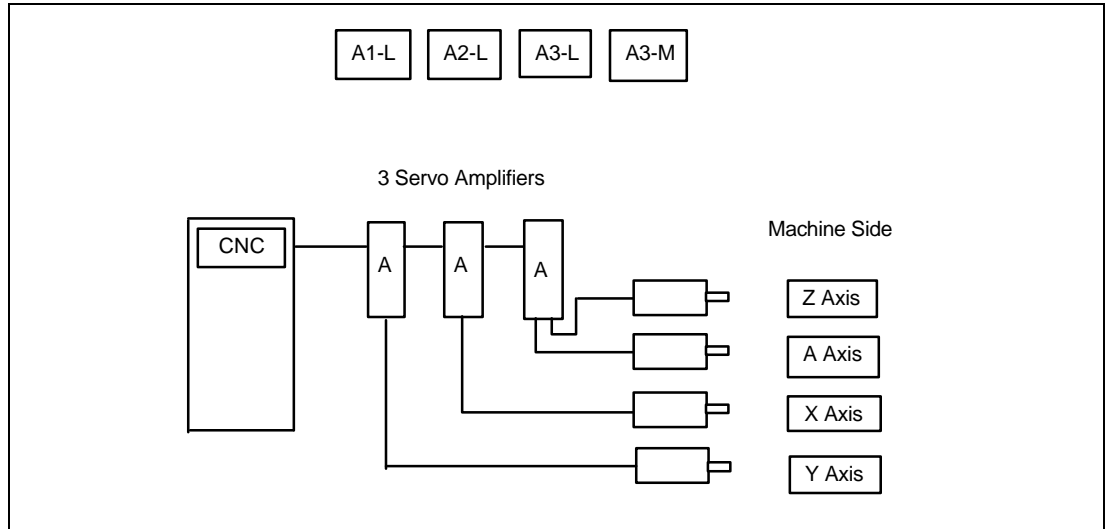

1. Set parameter No. 1023 as follows:

```

X : 1
Y : 2
Z : 3
A : 4
C : -1
    
```

2. Set the servo initial setting for each axis.
3. Turn power to the CNC OFF and then ON.
4. Enter the axis number on the Amplifier Setting screen.

AMPLIFIER SETTING						
NO.	AMP	SERIES	UNIT	CUR.	[AXIS]	NAME
1	A1-L	α	SVM	40A	[2]	Y
2	A2-L	α	SVM	40A	[1]	X
3	A3-L	α	SVM	40A	[4]	A
4	A3-M	α	SVM	80A	[3]	Z
NO.	EXTRA	TYPE	PCB	ID		
>						
MDI	****	***	***		13:11:56	
	[AMP]	[AXIS]	[MAINTEN]	[]	[(OPRT)]	

Tandem Control Example (Master = X Axis; Slave = A Axis)

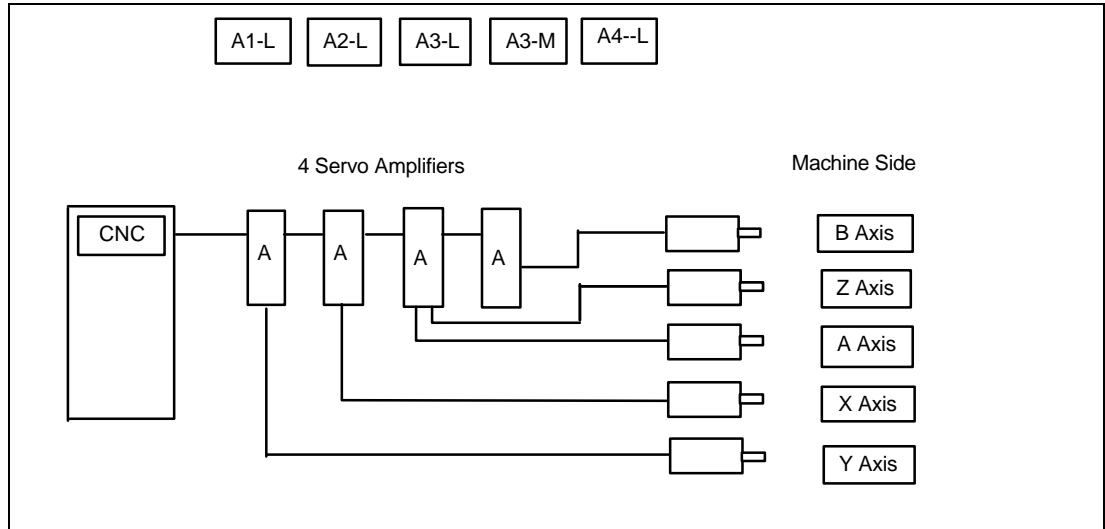

1. Set parameter No. 1023 as follows:

```

X : 1
Y : 3
Z : 5
A : 2
B : 4
    
```

2. Set the servo initial setting for each axis.
3. Turn power to the CNC OFF and then ON.
4. Enter the axis number on the Amplifier Setting screen.

AMPLIFIER SETTING						
NO.	AMP	SERIES	UNIT	CUR.	[AXIS]	NAME
1	A1-L	α	SVM	40A	[2]	Y
2	A2-L	α	SVM	40A	[1]	X
3	A3-L	α	SVM	40A	[4]	A
4	A3-M	α	SVM	80A	[3]	Z
5	A4-L	α	SVM	40A	[5]	B
NO.	EXTRA	TYPE	PCB	ID		
>						
MDI	****	***	***	13:11:56		
[AMP]	[AXIS]	[MAINT]	[]	[(OPRT)]		

Electrical Gear Box Function Example

In this example, the Electrical Gear Box works the A axis, and the Electrical Gear Box dummy works the B Axis (Parameter No. 7771=5).

Caution

For the Electrical Gear Box Function, set parameter No. 7771 first. Then, proceed with the Automatic setting on the FSSB Setting screen. If you do not set parameter No. 7771 first, the Automatic setting will not be done correctly.

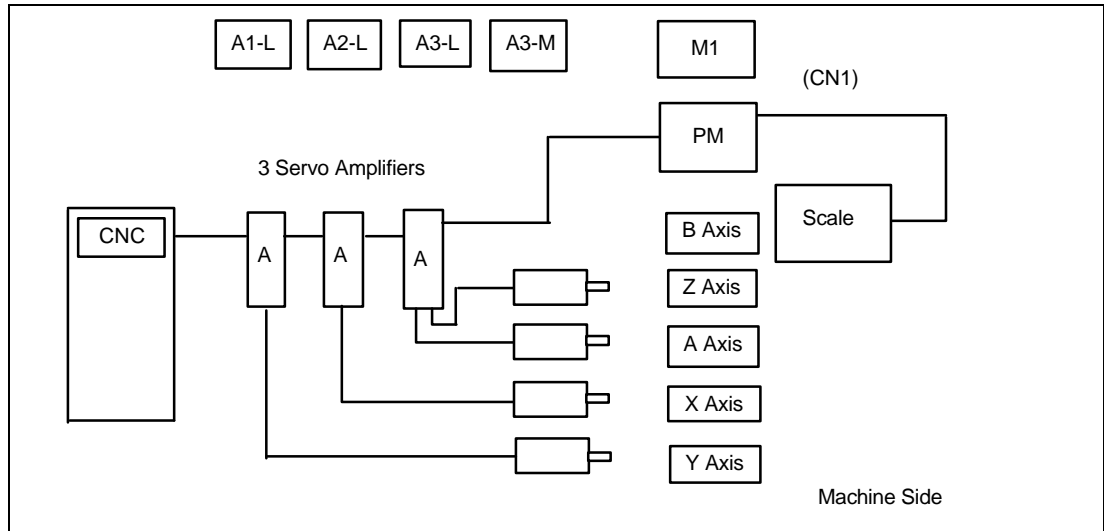

1. Set parameter No. 1023 as follows:

X	:	1	(No. 7771=5)
Y	:	2	(No. 7772)
Z	:	5	(No. 7773)
A	:	3	(No. 2011#0=1) (A Axis, B Axis)
B	:	4	
2. Set the servo initial setting for each axis.
3. Turn power to the CNC OFF and then ON.

- Enter the axis number on the Amplifier Setting screen.

AMPLIFIER SETTING						
NO.	AMP	SERIES	UNIT	CUR.	[AXIS]	NAME
1	A1-L	α	SVM	40A	[2]	Y
2	A2-L	α	SVM	40A	[1]	X
3	A3-L	α	SVM	40A	[4]	A
4	A3-M	α	SVM	80A	[3]	Z
NO.	EXTRA	TYPE	PCB	ID		
5	M1	A	0008	DETECTOR(4AXES)		
>						
MDI	****	***	***	13:11:56		
[AMP]	[AXIS]	[MAINT]	[]	[(OPRT)]		

- Press the **[SETTING]** soft key.
- Press the **SYSTEM** function key.
- Press the  key several times to display the **[FSSB]** soft key. Then, press the **[FSSB]** soft key to change the Amplifier Setting screen.
- Press the **[AXIS]** soft key.

AXIS SETTING							
AXIS	NAME	AMP	M1	M2	1-DSP	Cs	TNDM
1	X	A2-L	0	0	0	0	0
2	Y	A1-L	0	0	0	0	0
3	Z	A3-M	0	0	0	0	0
4	A	A3-L	0	0	0	0	0
5	B	-	1	0	0	0	0
>							
MDI	****	***	***	13:11:56			
[AMP]	[AXIS]	[MAINT]	[]	[(OPRT)]			

- Press the **[SETTING]** soft key. The setting will be complete after you turn the CNC OFF and then ON.

Manual Setting

Parameter No. 1905, 1910 – 1919, 1936, and 1937 may be set manually.

Refer to Chapter 4, "Description of Parameters," for information on each parameter before attempting to change or set a parameter manually.

An example using the Manual setting is provided on the next page.

Example: Axis Configuration and Parameter Settings

When parameter No. 1902 is set as shown below, you can then set the parameters for each axis manually:

Parameter No. 1902#0=1
 Parameter No. 1902#1=0

Note

When parameter No. 1902 is set, parameter No. 1023, 1905, 1910 – 1919, 1936, and 1937 must be set manually.

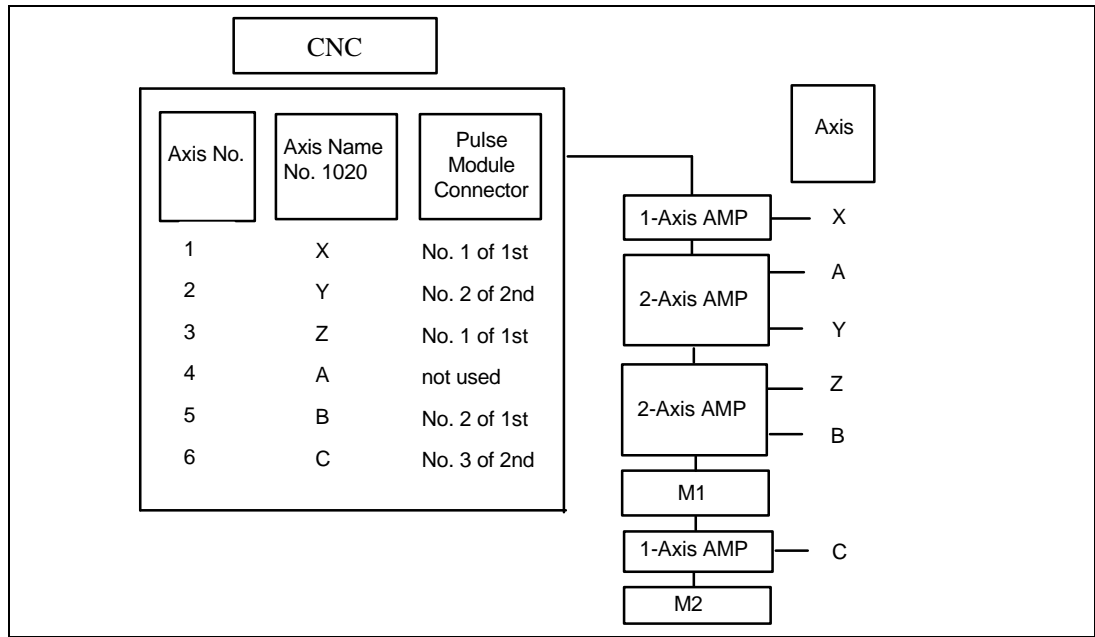

No.	1902#0
	1

No.	1910	1911	1912	1913	1914	1915	1916	1917	1918	1919
	0	1	2	3	4	16	5	48	40	40

No.	1023	1905#0	1905#6	1905#7	1936	1937
X	1	0	1	0	0	0
Y	3	0	0	1	0	1
Z	4	1	0	1	0	0
A	2	1	0	0	0	0
B	5	0	1	0	1	0
C	6	1	0	1	0	2

Chapter 4

Description of Parameters

Parameter No. 1902

No.	7	6	5	4	3	2	1	0
1902							ASIGN	FSBMD

Data Type: Bit

Parameter	Setting	Description
FSBMD	0	Automatic setting mode. After the axis information is entered on the FSSB Setting screen, parameter No. 1023, 1905, 1910 - 1919, 1936, and 1937 are set automatically.
	1	Manual setting mode. You must enter parameter No. 1023, 1905, 1910 - 1919, 1936, and 1937 manually.
ASIGN	0	Automatic setting is completed.
	1	Automatic setting is not completed. Note: When the automatic setting is done, this bit automatically becomes 1.

Parameter No. 1904

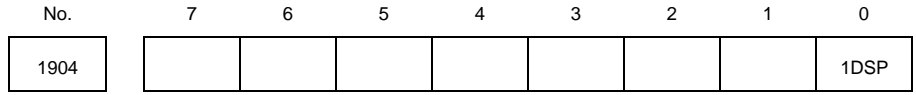

Data Type: Bit Axis

Parameter	Setting	Description
1DSP	0	An axis uses a DSP with another axis.
	1	An axis uses a DSP without any other axis (e.g., the learning control axis).

Note

Do not set this bit manually because this bit is set by the FSSB setting screens. It is not necessary to set this bit when the FSSB setting screens are not used.

Parameter No. 1905

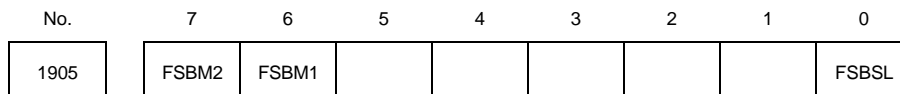

Data Type: **Bit Axis**

Parameter	Setting	Description
FSBSL	0	The servo data transmission interface is Fast type.
	1	The servo data transmission interface is Slow type.
FSBM1	0	The first pulse module is not used.
	1	The first pulse module is used.
FSBM2	0	The second pulse module is not used.
	1	The second pulse module is used.

Note

When parameter No. 1902#0=0, these bits are set automatically. When parameter No. 1902#0=1, these bits must be set manually. When using the pulse module, you must also set the connector number for parameter No. 1936 and 1937.

Interface Type

There are two types of interface (Fast and Slow) for transferring servo data. Each type **must** accept all of the following conditions:

- For a one-axis amplifier, either type (Fast or Slow) is accepted.
- For a two-axis amplifier, a combination of Fast-Fast cannot be used. Use Fast-Slow, Slow-Fast, or Slow-Slow.
- For a three-axis amplifier, the first and second axes are applied to a two-axis amplifier, and the third axis is applied to a one-axis amplifier.
- The axis whose value of parameter No. 1023 is odd uses the Fast type interface.
- The axis whose value of parameter No. 1023 is even can use only the Slow type interface.
- The EGB work axis, the learning control axis, the 125 μs current loop control axis, and the high-speed interface axis can use the Slow type.

Example for Figure 1905

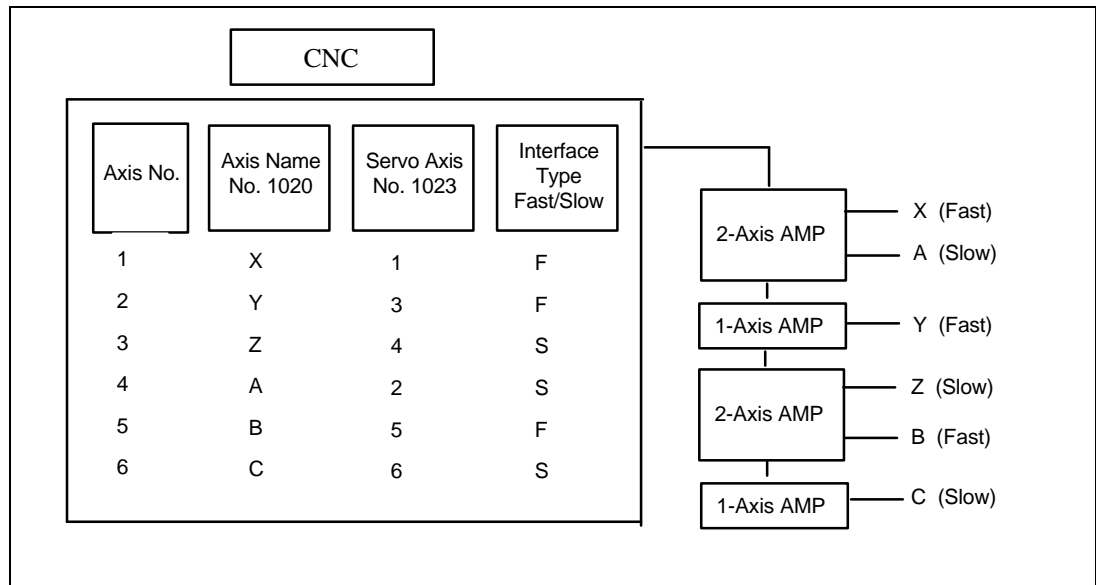

Parameter No. 1910 – 1919

No.	
1910	The value of the Address Conversion Table (ATR) for Slave No. 1
1911	The value of the Address Conversion Table (ATR) for Slave No. 2
1912	The value of the Address Conversion Table (ATR) for Slave No. 3
1913	The value of the Address Conversion Table (ATR) for Slave No. 4
1914	The value of the Address Conversion Table (ATR) for Slave No. 5
1915	The value of the Address Conversion Table (ATR) for Slave No. 6
1916	The value of the Address Conversion Table (ATR) for Slave No. 7
1917	The value of the Address Conversion Table (ATR) for Slave No. 8
1918	The value of the Address Conversion Table (ATR) for Slave No. 9
1919	The value of the Address Conversion Table (ATR) for Slave No. 10

Data Type: Byte

Data Range: 0 - 7, 16, 40, 18

The ATR for each slave must be set. A slave consists of a servo amplifier and pulse module connected to the CNC by an optical cable. A 2-axis amplifier has two slaves, and a 3-axis amplifier has three slaves. Each slave is assigned a number, from 1 to 10, according to its distance from the CNC.

- For an amplifier, set the value which is one less than the value of parameter No. 1023.
- For a pulse module, set 16 for the first pulse module (closest to the CNC) and 48 for the second pulse module (farthest from the CNC).
- If there is no slave, set 40.
- For the Electric Gear Box function, the EGB dummy axis, designated in parameter No. 7771, does not require an amplifier. However, do not set 40. Instead, set the values which is one smaller than the value of parameter No. 1023 for the EGB axis.

Note

When parameter No. 1902#0=0, these bits are set automatically. When parameter No. 1902#0=1, these bits must be set manually.

Examples of Axis Configuration and Parameter Settings

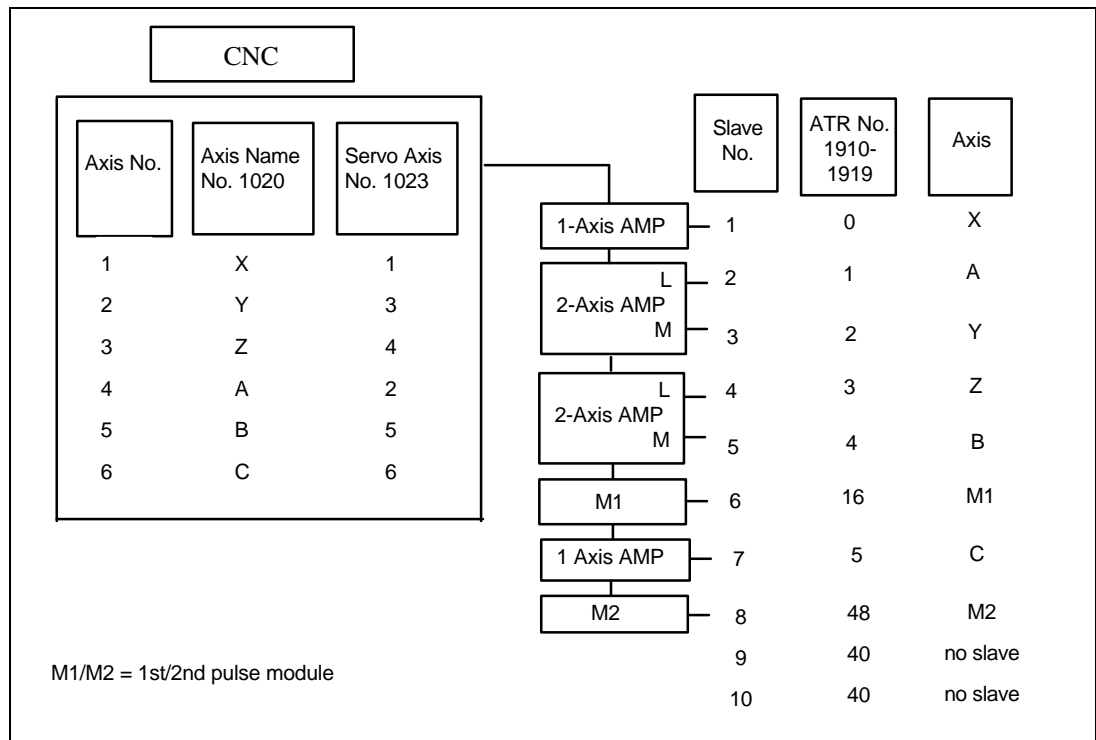

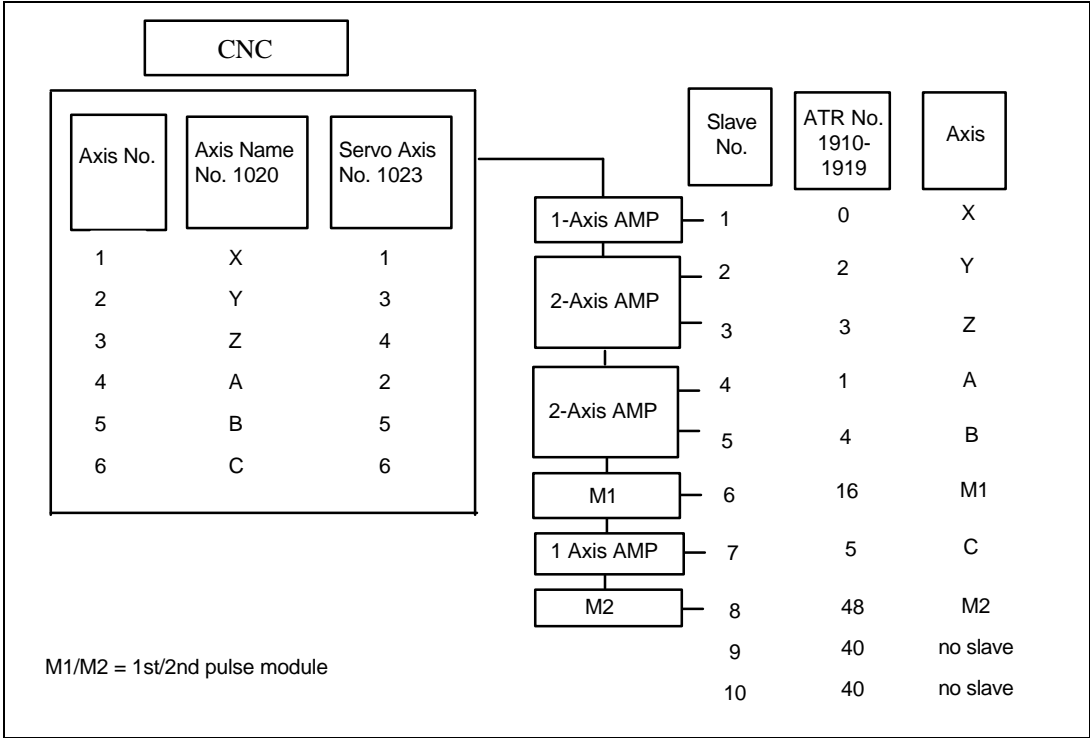

Example: Electronic Gear Box (EGB) Function

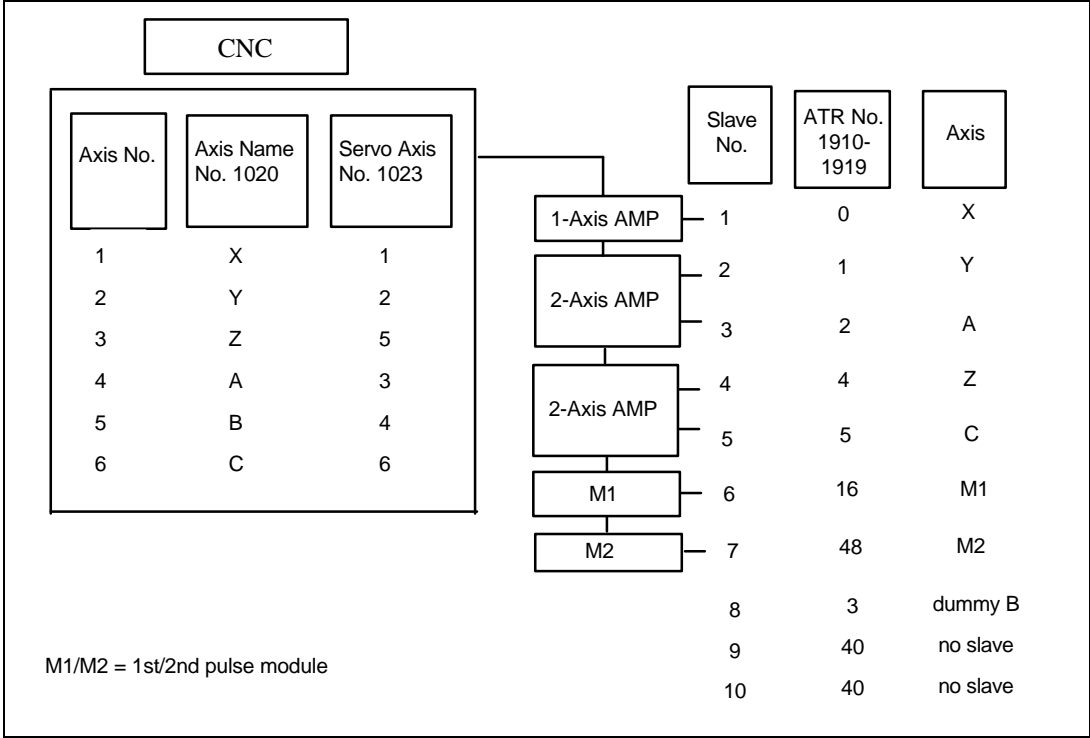

Parameter No. 1920 – 1929

No.	
1920	Axis number for Slave No. 1 (for the FSSB setting screens)
1921	Axis number for Slave No. 2 (for the FSSB setting screens)
1922	Axis number for Slave No. 3 (for the FSSB setting screens)
1923	Axis number for Slave No. 4 (for the FSSB setting screens)
1924	Axis number for Slave No. 5 (for the FSSB setting screens)
1925	Axis number for Slave No. 6 (for the FSSB setting screens)
1926	Axis number for Slave No. 7 (for the FSSB setting screens)
1927	Axis number for Slave No. 8 (for the FSSB setting screens)
1928	Axis number for Slave No. 9 (for the FSSB setting screens)
1929	Axis number for Slave No. 10 (for the FSSB setting screens)

Data Type: Byte

Data Range: 0 - 8

The axis number for each slave is set.

Note

Do not set these parameters manually because these parameters are set with the FSSB setting screens. It is not necessary to set these parameters when the FSSB setting screens are not used.

Parameter No. 1931 – 1932

No.	
1931	Connector number for the first pulse module (for the FSSB setting screens)
1932	Connector number for the second pulse module (for the FSSB setting screens)

Data Type: Byte Axis

Data Range: 0 - the number of each pulse module connectors

When the pulse module is used, the connector number is set.

Note

Do not set these parameters manually because these parameters are set with the FSSB setting screens. It is not necessary to set these parameters when the FSSB setting screens are not used.

Parameter No. 1933

No.	
1933	Cs contour control axis (for the FSSB setting screens)

Data Type: Byte Axis

Data Range: 0, 1

When the Cs contour control is used, set 1 for the Cs contour control axis.

Note

Do not set these parameters manually because these parameters are set with the FSSB setting screens. It is not necessary to set these parameters when the FSSB setting screens are not used.

Parameter No. 1934

No.	
1934	Tandem control master/slave axis number (for the FSSB setting screens)

Data Type: Byte Axis

Data Range: 0 - 8

When tandem control is used, assign two consecutive numbers, one odd and the other even, to the master and slave axes.

Note

Do not set these parameters manually because these parameters are set with the FSSB setting screens. It is not necessary to set these parameters when the FSSB setting screens are not used.

Parameter No. 1936 – 1937

No.	
1936	Connector number for the first pulse module
1937	Connector number for the second pulse module

Data Type: Byte Axis

Data Range: 0 - 7

For a pulse module, set a value which is one less than the connector number for each axis. Use zero (0) for an axis where the pulse module is not used.

You can use any combination of axis and connector, but you must use the lowest available number. For example, you cannot use Connector No. 3 without using No. 2.

Example:

Axis	1st Module Connector No.	2nd Module Connector No.	No. 1936	No. 1937	No. 1905 (#7, #6)
X	1	not used	0	0	0, 1
Y	not used	2	0	1	1, 0
Z	not used	1	0	0	1, 0
A	not used	not used	0	0	0, 0
B	2	not used	1	0	0, 1
C	not used	3	0	2	1, 0

Note

When parameter No. 1902#0=0, these bits are set automatically. When parameter No. 1902#0=1, these bits must be set manually.

Chapter 5

Troubleshooting

Pulse Coder

Number of NC Alarms	Message	Meaning
360	n axis : abnormal checksum (int)	Checksum alarm occurred in the pulse coder (int).
361	n axis : abnormal phase data (int)	Abnormal phase data alarm occurred in the pulse coder (int).
362	n axis : abnormal rev. data (int)	Abnormal rev. data alarm occurred in the pulse coder (int).
363	n axis : abnormal clock (int)	Clock alarm occurred in the pulse coder (int).
364	n axis : soft phase alarm (int)	Internal pulse coder data is abnormal.
365	n axis : broken LED (int)	Pulse coder LED is abnormal
366	n axis : pulse miss (int)	Pulse miss alarm occurred in the pulse coder (int).
367	n axis : count miss (int)	Count miss alarm occurred in the pulse coder (int).
368	n axis : serial data error (int)	Serial data was not received from the internal pulse coder.
369	n axis : data transmission error (int)	CRC error or stop bit error occurred in the pulse coder (int).
380	n axis : broken LED (ext)	External pulse coder LED is abnormal.
381	n axis : abnormal phase (ext lin)	Abnormal phase data alarm occurred in the external linear scale.
382	n axis : count miss (ext)	Count miss alarm occurred in the external pulse coder.
383	n axis : pulse miss (ext)	Pulse miss alarm occurred in the external pulse coder.
384	n axis : soft phase alarm (ext)	External pulse coder data is abnormal.
385	n axis : serial data error (ext)	Serial data was not received from the external pulse coder.
386	n axis : data transmission error (ext)	External pulse coder data is CRC error or stop bit error

Servo Amplifier

Number of NC Alarms	Message	Meaning
430	n axis : servo motor overheat	Servo motor overheated.
431	n axis : cnv. overload (OH)	Temperature of the converter (PSM) is abnormally high.
432	n axis : cnv. lowvolt con./powfault (LV)	Control circuit power supply is abnormally low.
433	n axis : cnv. low volt DC link (DCLV)	DC voltage of the voltage main circuit power supply is abnormally low, or the outer circuit breaker trips.
436	n axis : softthermal (OVC)	Overheat alarm detected by the software.
438	n axis : inv. abnormal current (HC)	Abnormal over-current flowed into the servo amplifier unit.
439	n axis : overvolt power (HV)	The DC voltage of the main circuit power supply is abnormally high.
440	n axis : cnv. ex deceleration pow. (DCOH)	The average regenerative discharge energy is too high (too frequent acceleration / deceleration).
441	n axis : abnormal current offset	Current feedback is abnormal.
443	n axis : cnv. cooling fan failure (FAL)	The fan, built into the servo amplifier unit, stopped.
445	n axis : soft disconnection alarm	Disconnection alarm detected by software.
446	n axis : hard disconnection alarm	Disconnection alarm detected by hardware (see note below).
447	n axis : hard disconnection (ext)	External pulse coder cable is disconnected.
448	n axis : unmatched feedback alarm	Feedback data of pulse coder was not matched to its external pulse coder.
460	n axis : FSSB disconnection	FSSB communication is open: 1. Optical fiber cable is open or disconnected. 2. Control power supply shut down. 3. LV alarm for the control power supply occurred.
461	n axis : illegal amp interface	Both axes are Fast interface in a 2-axis amplifier.
462	n axis : send CNC data failed	The slave side amplifier did not receive normal data because of an FSSB communication error.
463	n axis : send slave data failed	The servo side amplifier did not receive normal data because of an FSSB communication error.
464	n axis : write ID data failed	The amplifier cannot write maintenance data on the maintenance screen.
465	n axis : read ID data failed	The amplifier cannot read maintenance data on the maintenance screen.
466	n axis : motor / amp combination	The value of the amplifier maximum current is illegal for the motor maximum current.
467	n axis : illegal setting of axis	The amplifier is set to two axes on the Axis Setting screen, but the following is not possible: 1. Learning control (PRM2008#5=1). 2. High current loop (PRM2004#0=1). 3. High interface axis (PRM2005#4=1)

Note: Hard disconnection alarm has not occurred to the Series 16C or 16I.
The possibility of FBAL (ALARM 1 Bit 1=1).
External hardware disconnection FBAL (ALARM 1 Bit 1=1, ALARM 2 Bit 7=1, Bit 4=1).
Software disconnection (ALARM 1 Bit 1=1).
Count miss error (ALARM 1 Bit 1=1, ALARM 2 Bit 7=1, ALARM 3 Bit 3=1).

P/S Alarm

Number of NC Alarms	Message	Meaning
5134	FSSB : open ready time out	FSSB is not ready when power is turned ON.
5135	FSSB : error mode	FSSB is abnormal.
5136	FSSB : number of amps is small	The number of the amplifier is smaller than the setting number.
5137	b : configuration error	FSSB has a configuration error.
5138	FSSB : axis setting not complete	The axis is not set in Auto mode.
5197	FSSB : open time out	FSSB is not communicating.
5198	FSSB : ID data not read	ID data was not read.

Frequently Asked Setup Questions

Question / Problem	Solution
Cannot input the parameter in MDI mode.	<p>Remember that you cannot input a parameter in MDI mode unless you cycle power , OFF and ON.</p> <p>After turning power OFF and then ON and disconnecting the optical cable on the CNC side, check the following items:</p> <ol style="list-style-type: none"> 1. Check parameter No. 1902: <ol style="list-style-type: none"> A. If No. 1902=00000000, set No. 1905=00000000 and No. 1910 - 1919=0. B. If No. 1902=00000001 or 00000010, set No. 1905 and No. 1910 - 1919 to the correct value. 2. If No. 1815 B1=1, check No. 1910 - 1919. If the value is not 16 or 48, set No. 1815 B1=0. 3. Check that the FSSB Ready to Operate green LED is ON. If not, check the power to the amplifier and the connection of the optical cable.
Although the outer detector is recognized on the FSSB, the feedback pulses are not correct.	<p>Check parameter No. 1902.</p> <ol style="list-style-type: none"> 1. If No. 1902=00000001, set No. 1905=01000000 or 10000000. Also set No. 1910 - 1919, 1936, and 1937 to the correct value. 2. If No. 1902=00000010, set the M0 and M1 connector numbers on the FSSB Axis screen.
Cannot input the M1 or M2 connector number on the FSSB Axis screen.	Check the ID of the pulse module on the FSSB screen. If the ID is not read correctly, check the connection of the separate detector interface unit.
The setting value on the FSSB screen changes the former setting value after turning power OFF/ON.	After inputting the value, remember to press the [SETTING] soft key on both the Amplifier and Axis Setting screens.
P/S Alarm 5138 occurred. (FSSB : axis set not complete)	<p>Automatic setting has not completed yet. After inputting the value, remember to press the [SETTING] soft key on both the Amplifier and Axis Setting screens.</p> <p>When using the manual setting, remember to set the parameters for No. 1902, 1905, 1910 - 1919, 1936, and 1937 to 0.</p>
SV Alarm 466 occurred. (n axis : motor / amp combination)	<ol style="list-style-type: none"> 1. Check the combination between the motor and amp. 2. Check the current value in parameter No. 2165 and the FSSB Amplifier screen. 3. Load the servo initial parameter.
System Alarm 920 occurred after changing parameter No. 1902 and turning power OFF and then ON.	<ol style="list-style-type: none"> 1. Disconnect the optical cable on the CNC side. 2. Turn power OFF and ON. 3. Set parameter No. 1902, 1905, 1910 - 1919, 1936, and 1937 to 0.
FSSB Automatic setting was not done successfully in a two-path control CNC.	Change CNC software (B0F1 / B1F1 / BDF1 / BEF1) version 04 or later.
The setting which uses the axis of another path in the two-path control CNC was not done successfully.	Change CNC software (B0F1 / B1F1 / BDF1 / BEF1) version 04 or later.

Appendix

A

Separate Type Detector Interface Unit

Appendix A contains A-73402E, *Separate Type Detector Interface Unit Connecting Manual (Preliminary)*.

This page intentionally left blank.

Separate type detector interface unit Connecting manual (PRELIMINARY)

Contents

1. Outline.
2. Types of the separate type detector interface unit.
3. Supply Voltage and Current.
4. Heat loss.
5. Connection diagram.
6. Details of connection.
 - 6.1. Connection of power line
 - 6.2. Linear scale interface (Parallel interface)
 - 6.3. Linear scale interface (Serial interface)
 - 6.4. Separate type pulse coder interface (Absolute type)
 - 6.5. Separate type pulse coder interface (Incremental type)
 - 6.6. Input signal requirements
 - 6.7. Connecting the battery for the separate type absolute pulse coder
 - 6.8. Connecting SDU1 and SDU2
7. Assembly.
 - 7.1. Requirement on assembling the units
 - 7.2. Size of the unit
 - 7.3. Connector layout
 - 7.4. Details of screw hole

FANUC

					TITLE Separate type detector interface unit Connecting manual (PRELIMINARY)
01	96.12.25	Y. Kubo			DRAW. NO. A-73402E
EDIT.	DATE	DESIG.	DESCRIPTION	FANUC LTD	SHEET 001/16

5.Connection diagram.

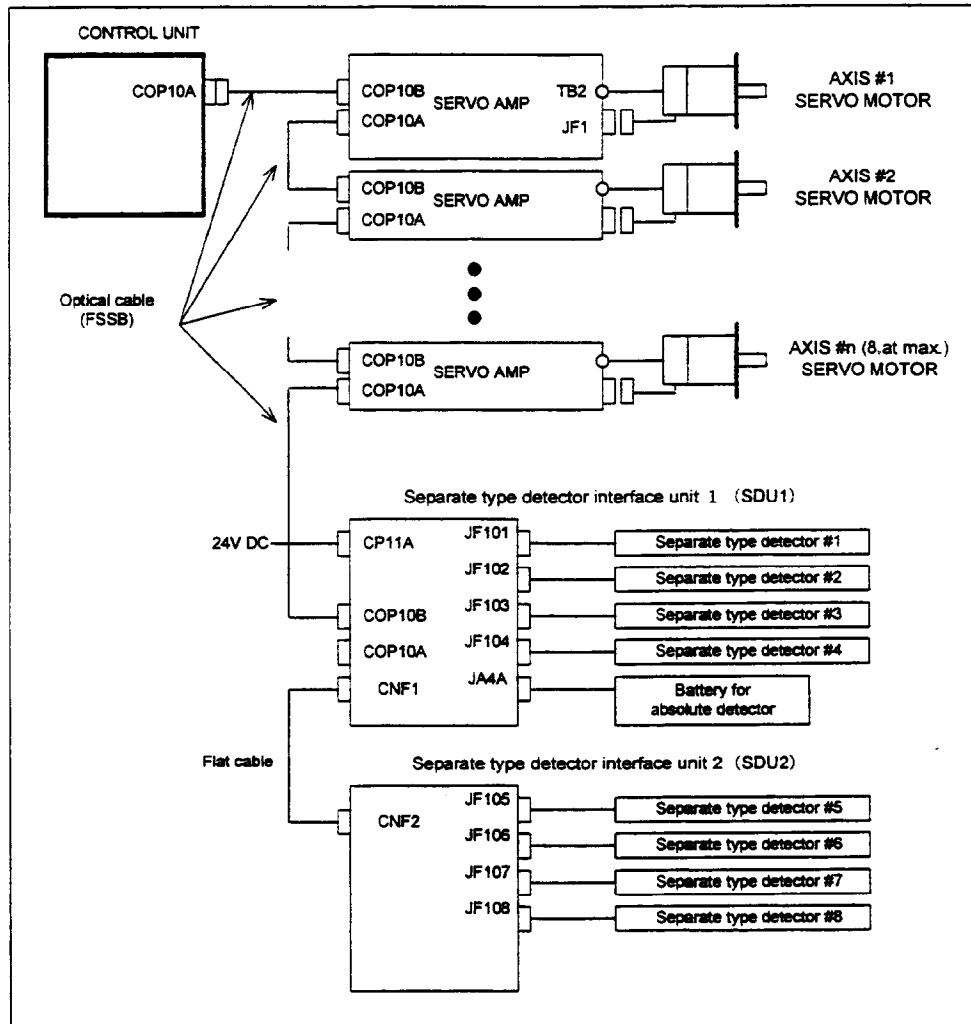

The SDU is connected to the CNC control unit via optical cable of "FANUC serial servo bus (FSSB)". Another units like servo amplifiers are also connected to the FSSB. In above figure, the SDU is connected as the last slave of the FSSB. Another configuration is also possible, that is the SDU can be inserted between the CNC control unit and the servo amplifier or between two servo amplifiers.

The signal from the separate type detector of the axis #1 is usually connected to JF101. In the same manner, signals corresponding to the axis #2 ~ #8 are connected to JF102 ~ JF108 respectively.

If necessary, the relationship between connectors JF101 ~ JF108 and axes numbered 1 ~ 8 can be varied. In above figure, when the axes numbered 2, 4, 6, 8 have the separate type detector, for example, the SDU2 does not need to be used by assigning the connector JF101 ~ JF104 of the SDU1 to the axis 2, 4, 6, 8. Please refer to the corresponding manual of the CNC controller for how to change the assignment.

				TITLE
				DRAW. NO. A-73402E CUST.
EDIT.	DATE	DESIG.	DESCRIPTION	FANUC LTD SHEET 003/

6.Details of connection.

6.1.Connection of power line

Supply power (24V DC) to the SDU1 from an external source.

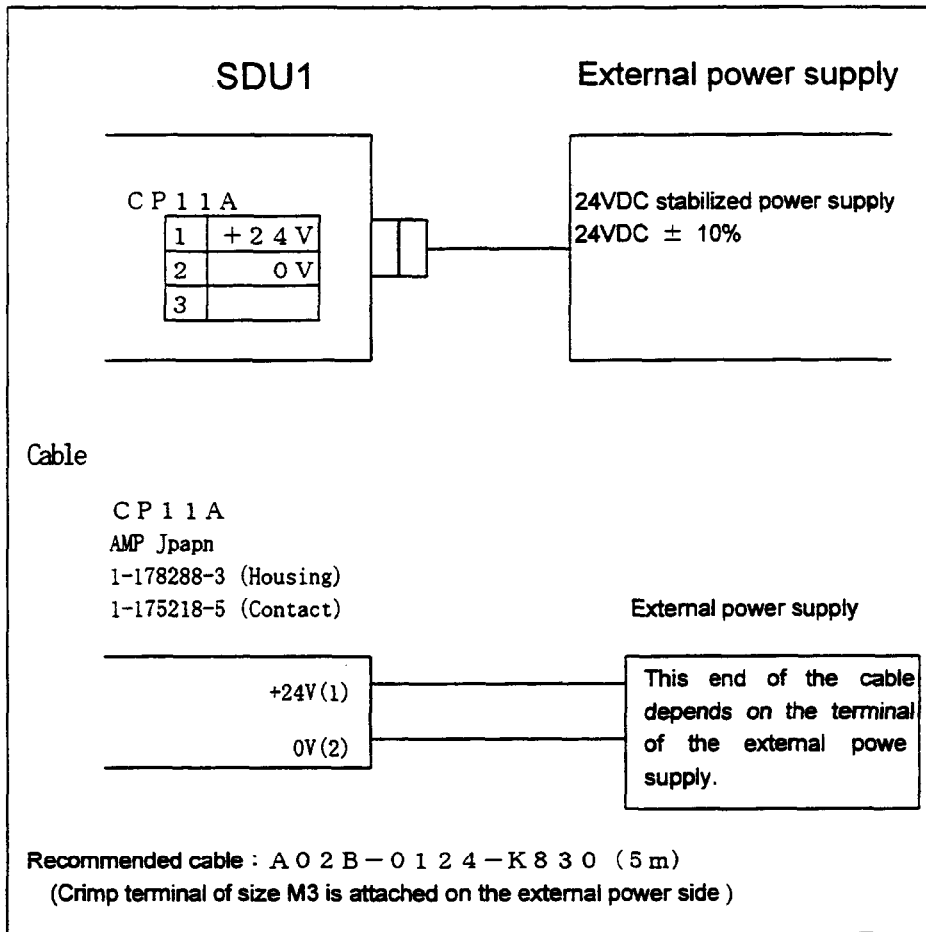

The power of 24V DC that is supplied into CP11A can be branched out from CP11B. Pins assignment ,connector housing, contacts are same as that of CP11A.

				TITLE
				DRAW. NO. A-73402E CUST.
EDIT.	DATE	DESIG.	DESCRIPTION	FANUC LTD SHEET 004/

6.2.Linear scale interface (Parallel interface)

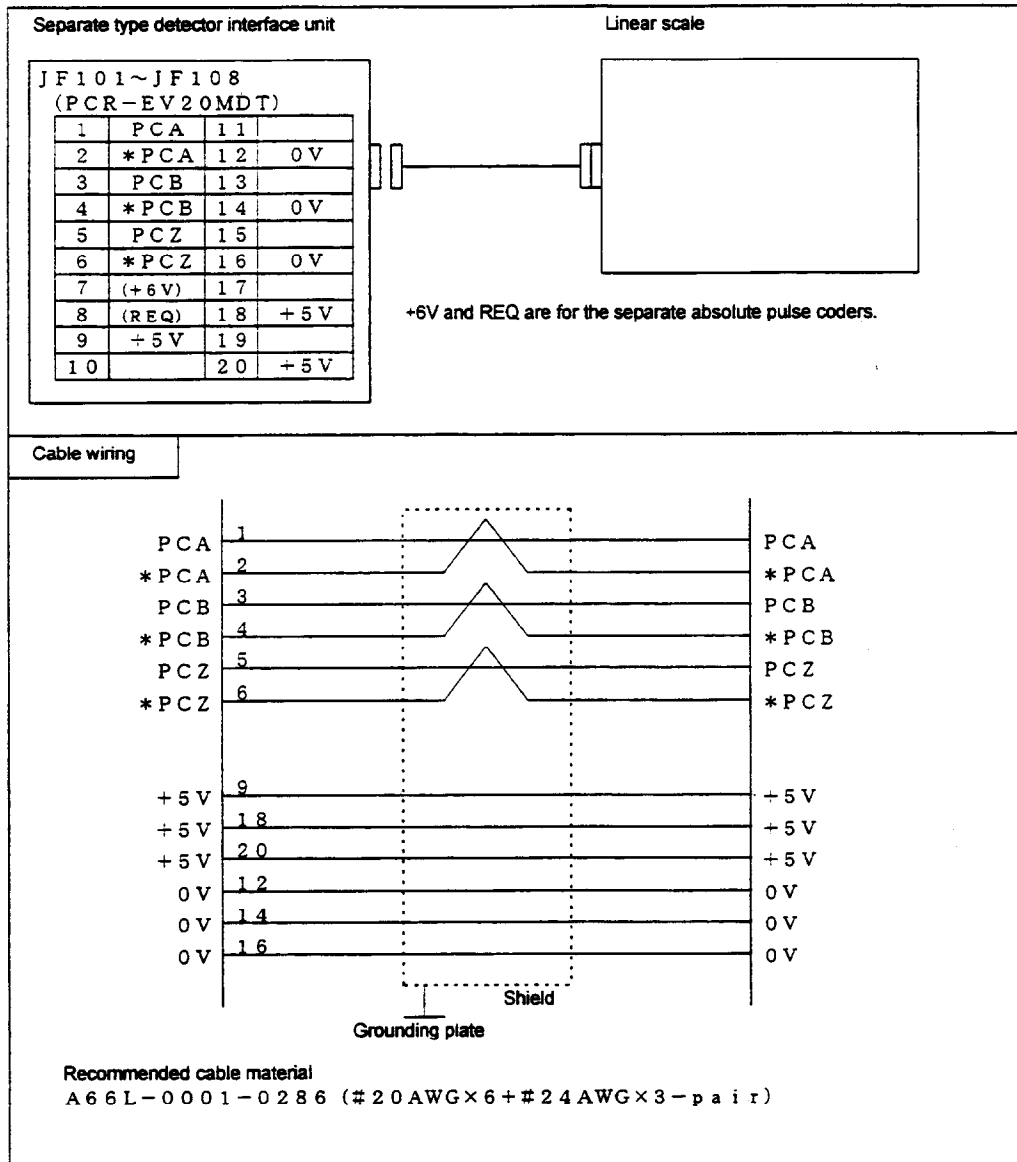

The power of +5V DC is available as the supplying power of the linear scales.
Maximum allowed current of +5V DC is 0.35A per a scale.

				TITLE
				DRAW. NO. A-73402E CUST.
EDIT.	DATE	DESIG.	DESCRIPTION	FANUC LTD SHEET 005/

6.3.Linear scale interface (Serial interface)

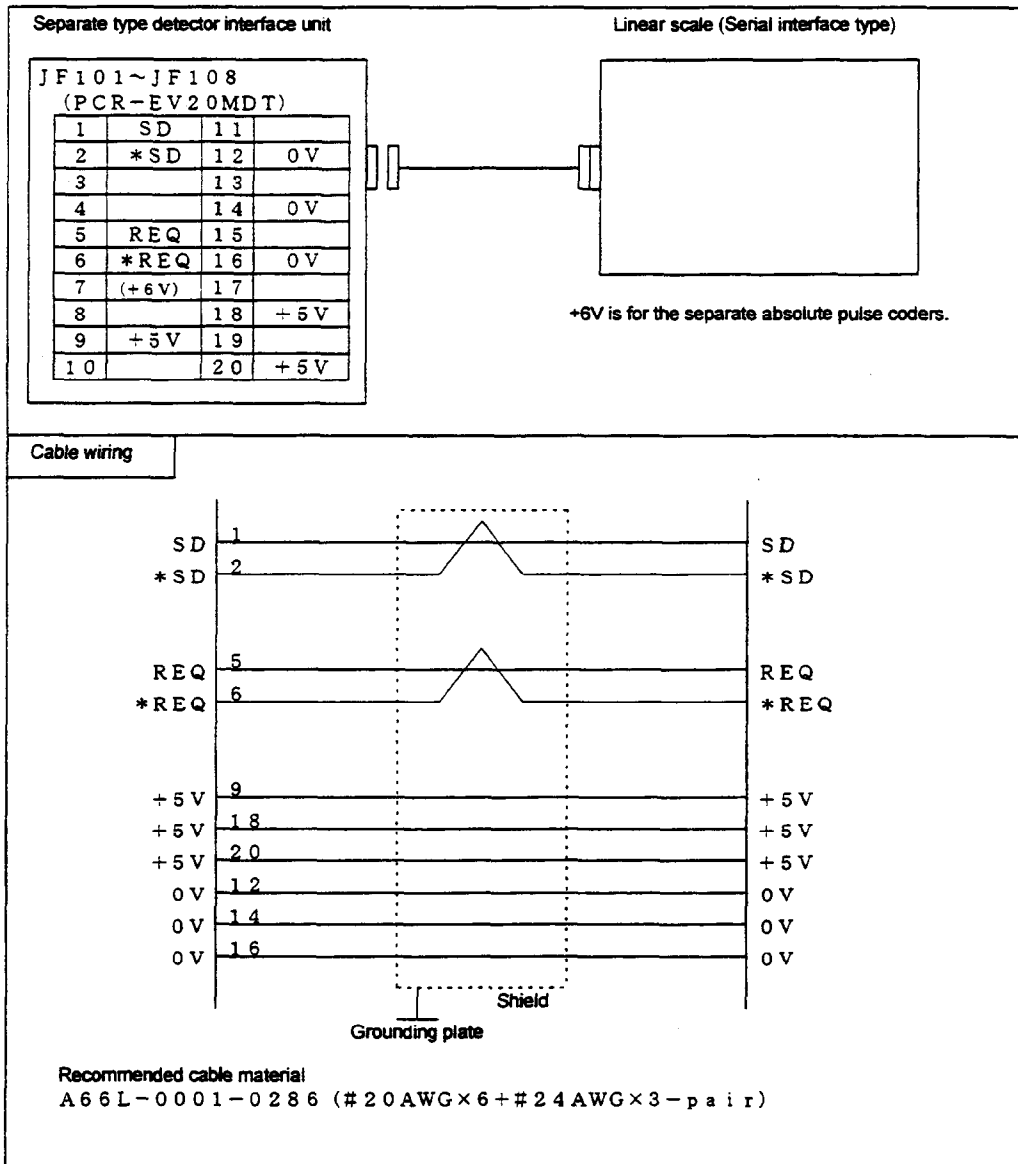

The power of +5V DC is available as the supplying power of the linear scales.
Maximum allowed current of +5V DC is 0.35A per a scale.

				TITLE
				DRAW. NO. A-73402E CUST.
EDIT.	DATE	DESIG.	DESCRIPTION	FANUC LTD SHEET 006/

6.4. Separate type pulse coder interface (Absolute type)

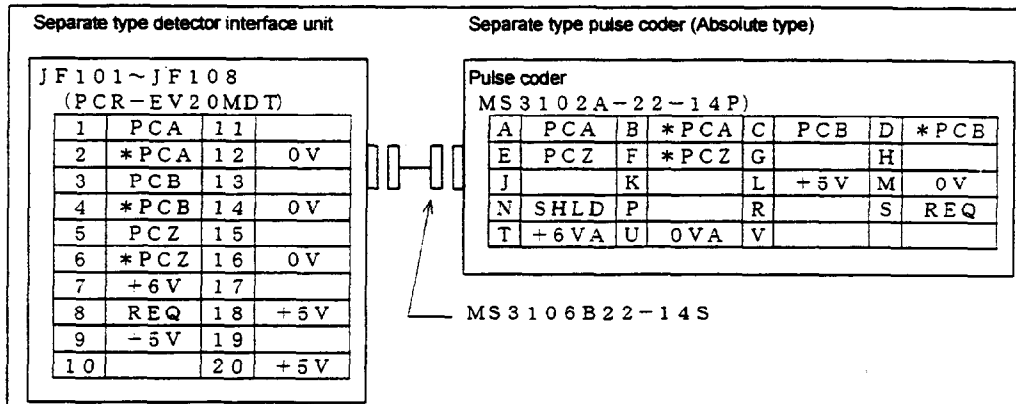

Cable wiring

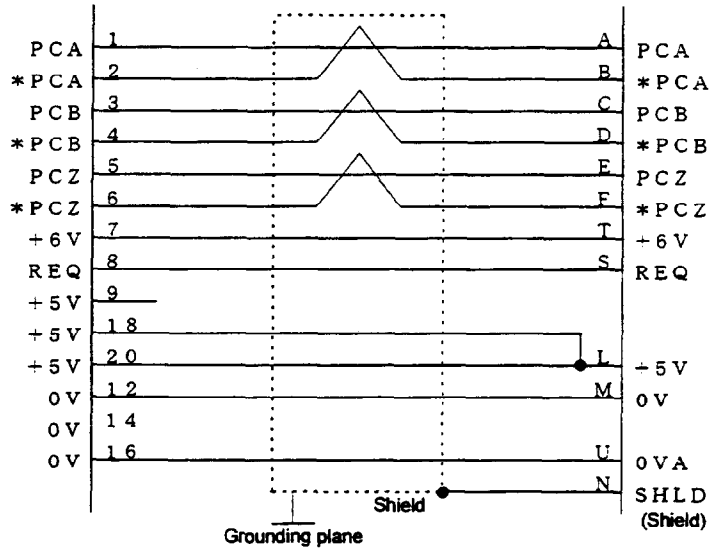

Recommended cable material

A66L-0001-0286 (#20AWG×6+#24AWG×3-pair)

				TITLE
				DRAW. NO. A-73402E CUST.
EDIT.	DATE	DESIG.	DESCRIPTION	FANUC LTD SHEET 007/

6.5. Separate type pulse coder interface (Incremental type)

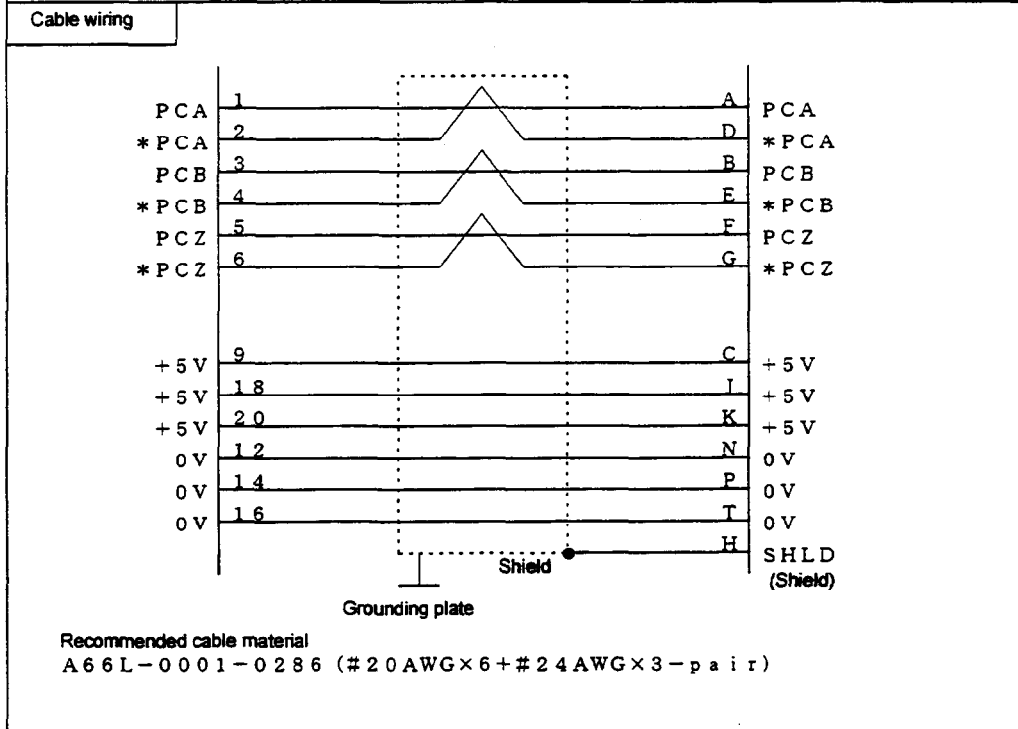
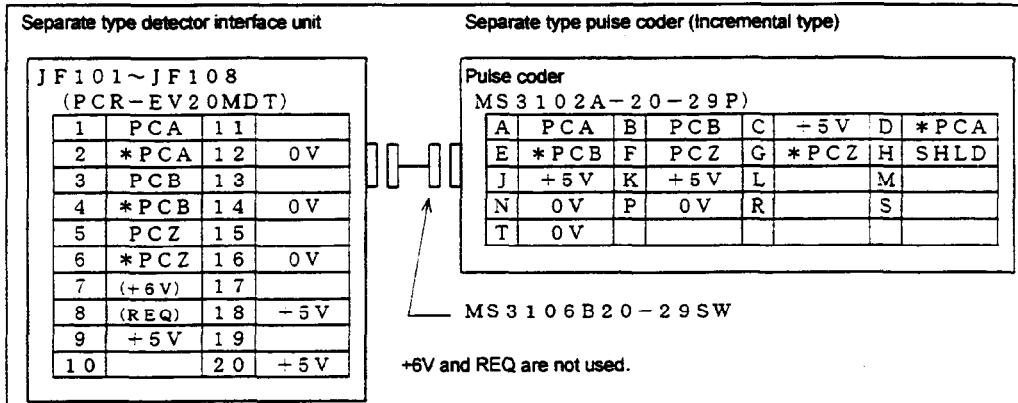

					TITLE
				DRAW. NO. A-73402E	CUST.
EDIT.	DATE	DESIG.	DESCRIPTION	FANUC LTD	SHEET 008/

6.6. Input signal requirements

(1) A and B phase signal input

This is a method to input position information by the mutual 90 degree phase slip of A and B phase signals. Detection of the position is performed with the state in which the B phase is leading taken as a shift in the plus direction, and the state in which the A phase is leading as a shift in the minus direction.

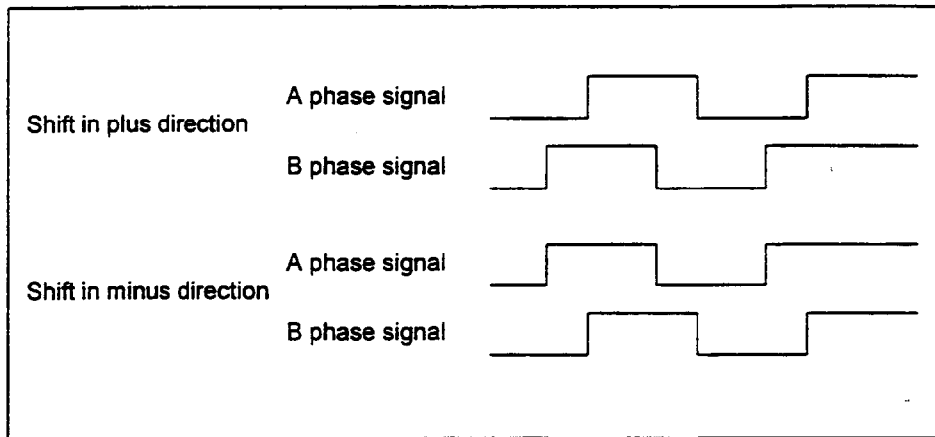

(2) Phase difference and minimum repeat frequency

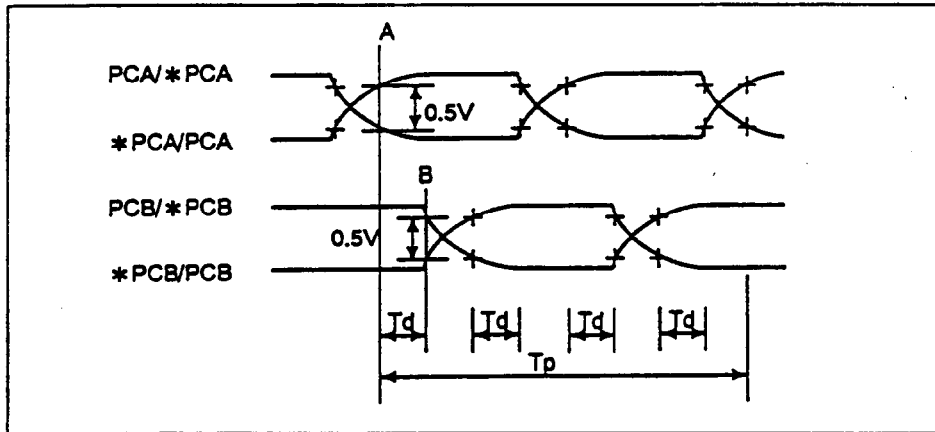

The minimum value of T_d in above diagram is

$$T_d \geq 0.15 \mu\text{sec}$$

The period and pulse width of the signals must be long enough to satisfy the above requirements.

				TITLE
				DRAW. NO. A-73402E
EDIT.	DATE	DESIG.	DESCRIPTION	FANUC LTD SHEET 009/

(3) Z phase signal input

For the Z phase signal (1 rotation signal), a signal width of more than 1 cycle of the A phase or B phase signals is necessary.

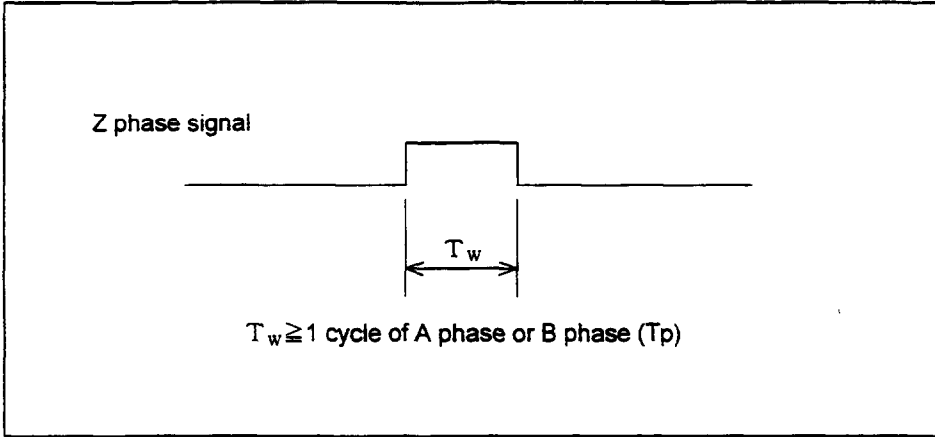

6.7. Connecting the battery for the separate type absolute pulse coder

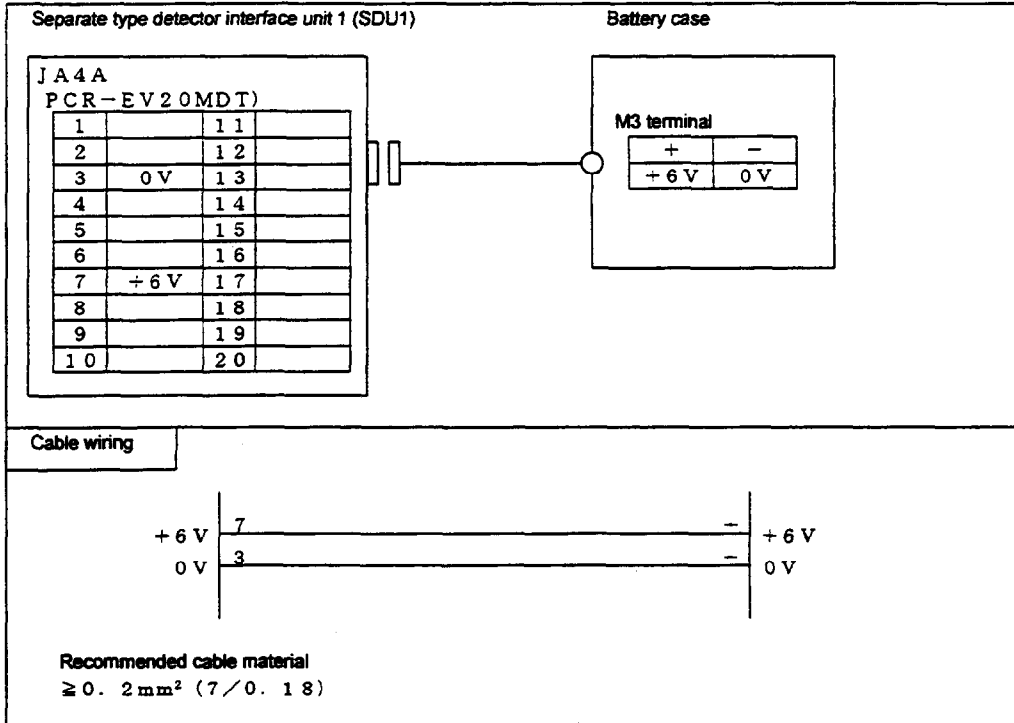

				TITLE
				DRAW. NO. A-73402E CUST.
EDIT.	DATE	DESIG.	DESCRIPTION	FANUC LTD SHEET 010/

6.8.Connecting SDU1 and SDU2

SDU1 and SDU2 are connected by a flat cable. The maximum length of the flat cable is 100mm.

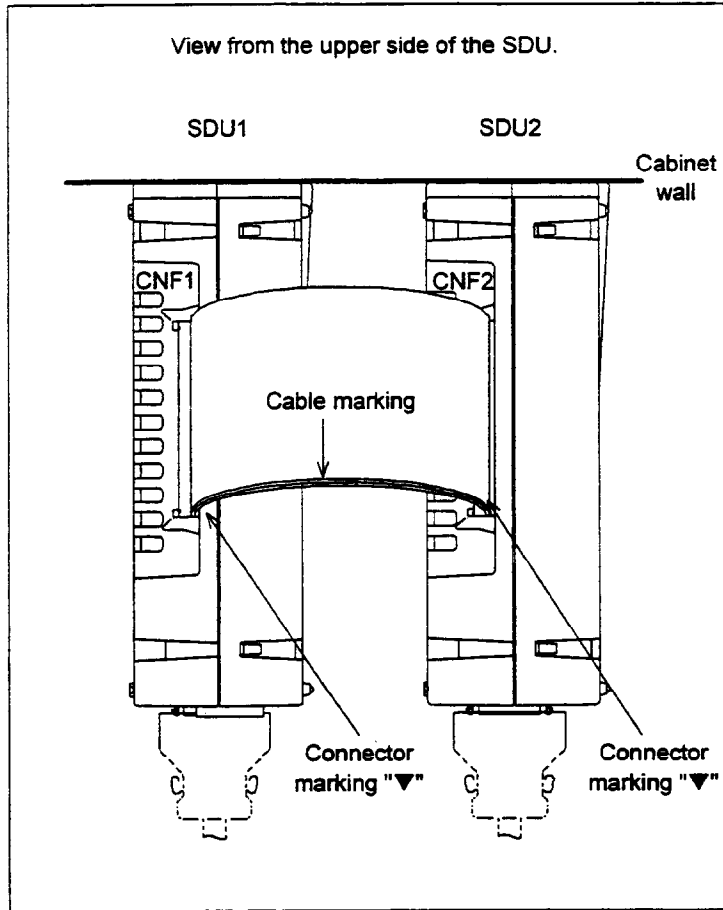

The flat cable should be ordered together with SDU1 and SDU2.

				TITLE
				DRAW. NO. A-73402E
EDIT.	DATE	DESIG.	DESCRIPTION	FANUC LTD
				SHEET 011/

7.Assembly.

7.1.Requirement on assembling the units

- (1) This unit should be installed in a cabinet that is always completely closed.
- (2) This unit should be fixed on the vertical wall in the cabinet. Clearances of 100mm or more both above and below the units are required.
Equipment radiating too much heat must not be put below the unit.
- (3) When both SDU1 and SDU2 are installed, they should be configured as shown in the figure below so that the flat cable should not cover the ventilation holes of the SDU1. Maximum length of flat cable is 100mm.

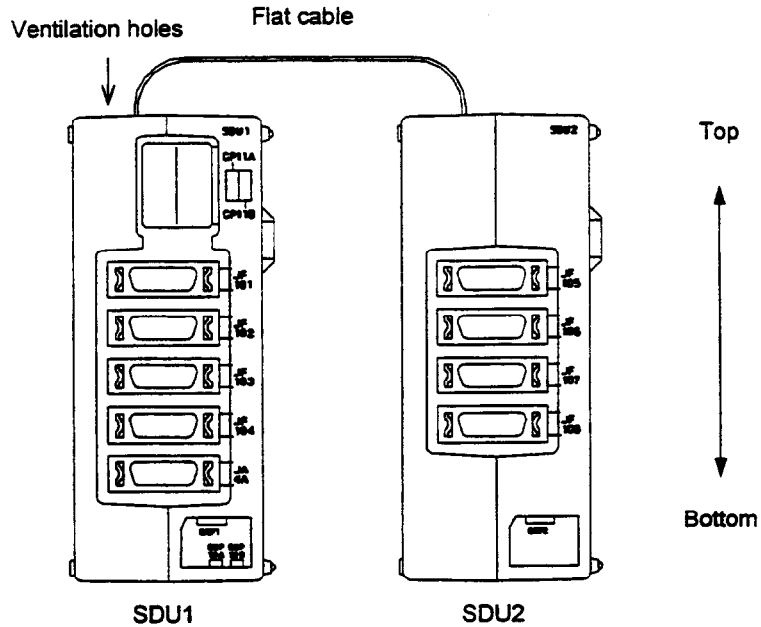

				TITLE
				DRAW. NO. A-73402E CUST.
EDIT.	DATE	DESIG.	DESCRIPTION	FANUC LTD SHEET 012/

7.2. Size of the unit

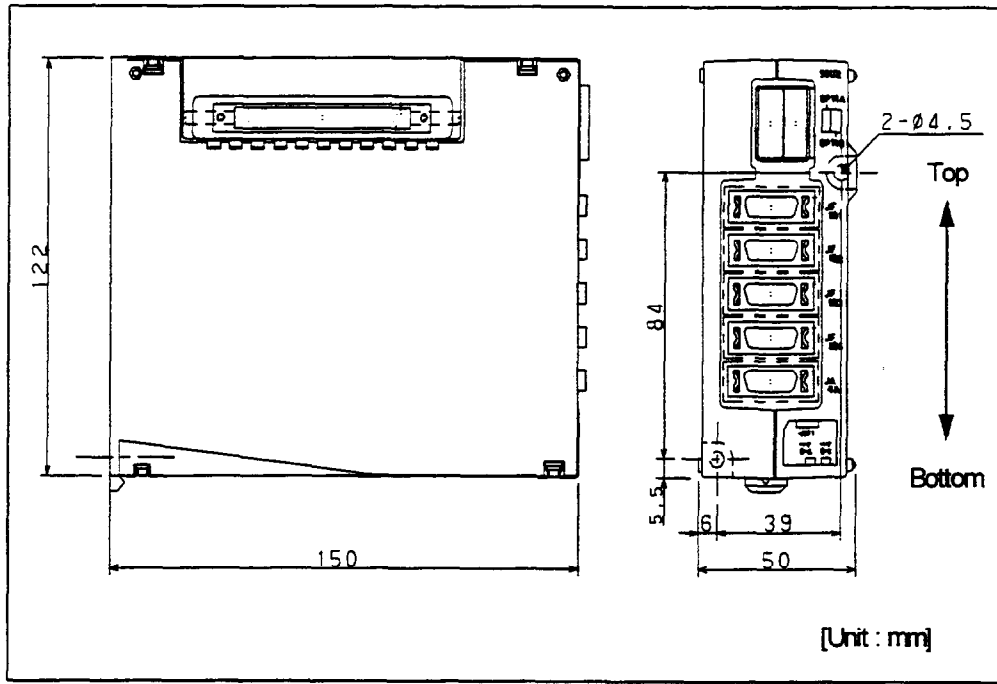

				TITLE	
				DRAW. NO. A-73402E	
				CUST.	
EDIT.	DATE	DESIG.	DESCRIPTION	FANUC LTD	SHEET 013/

7.3.Connector layout

Connector layout of the SDU1

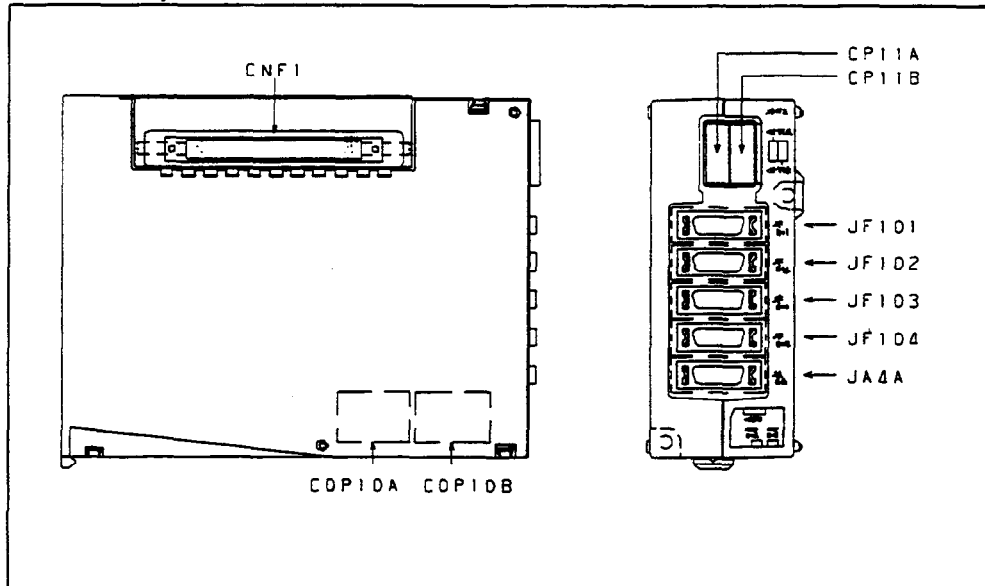

Connector layout of the SDU2

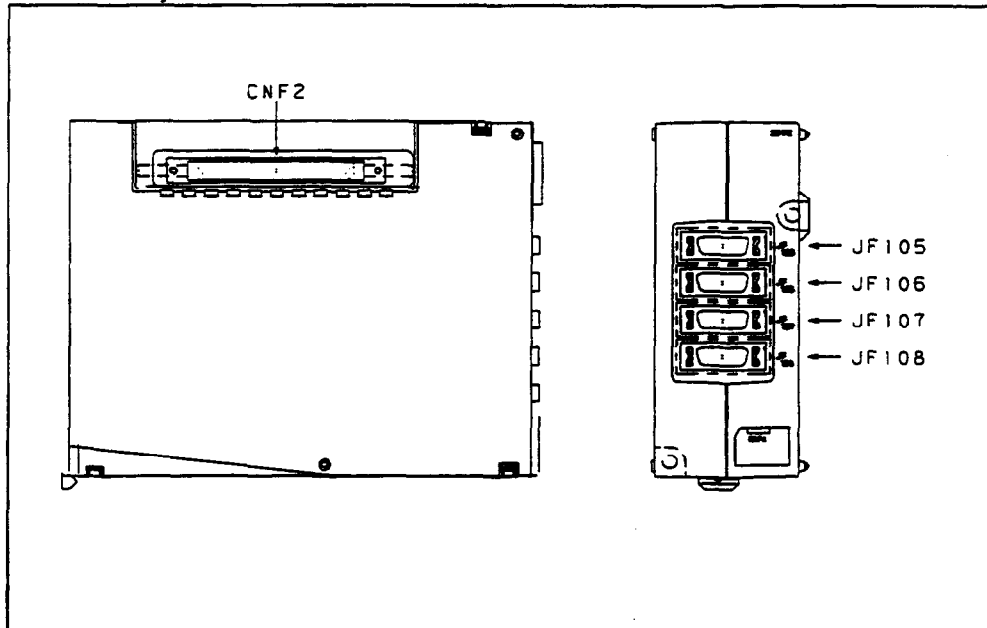

				TITLE
				DRAW. NO. A-73402E
EDIT.	DATE	DESIG.	DESCRIPTION	CUST. SHEET 014/
				FANUC LTD

7.4.Details of screw hole

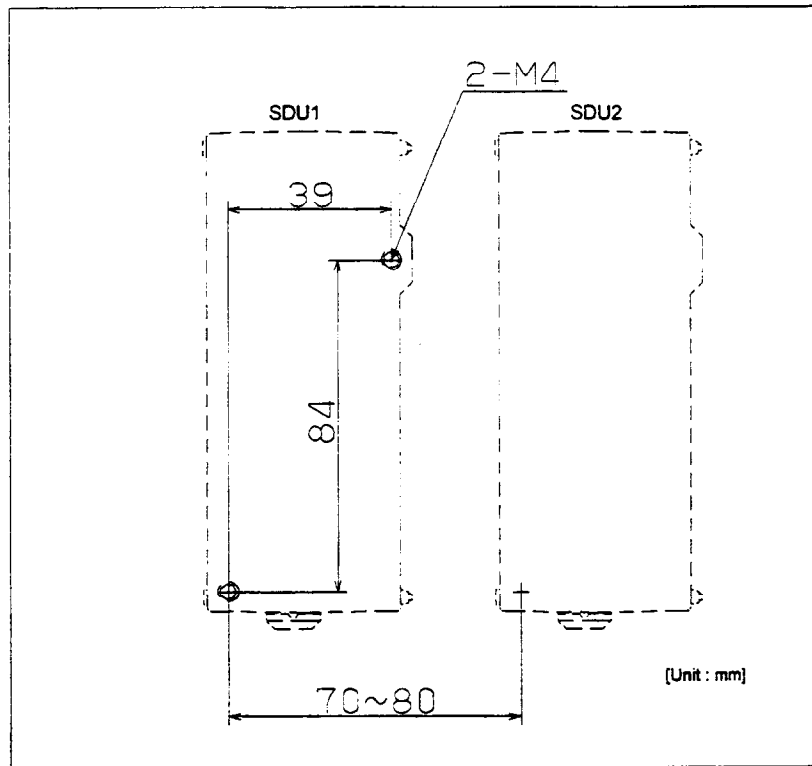

Drilling works of screw hole

When both SDU1 and SDU2 are installed, the space between screw hole of two units should be 70 to 80 mm.

				TITLE	
				DRAW. NO. A-73402E	
				CUST.	
EDIT.	DATE	DESIG.	DESCRIPTION	FANUC LTD	SHEET 015/

Note

An enough maintenance area is necessary for both sides of the unit. Because, the space to insert the screw driver diagonally is necessary (see the figure below).

As guideline, when the depth of the neighbor units are same as or less than the SDU, the clearance of 20mm is required. When the depth of the neighbor units are much more than the SDU, the clearance of 70mm is required.

The clearance of 70mm is also required between the SDU and the cabinet wall.

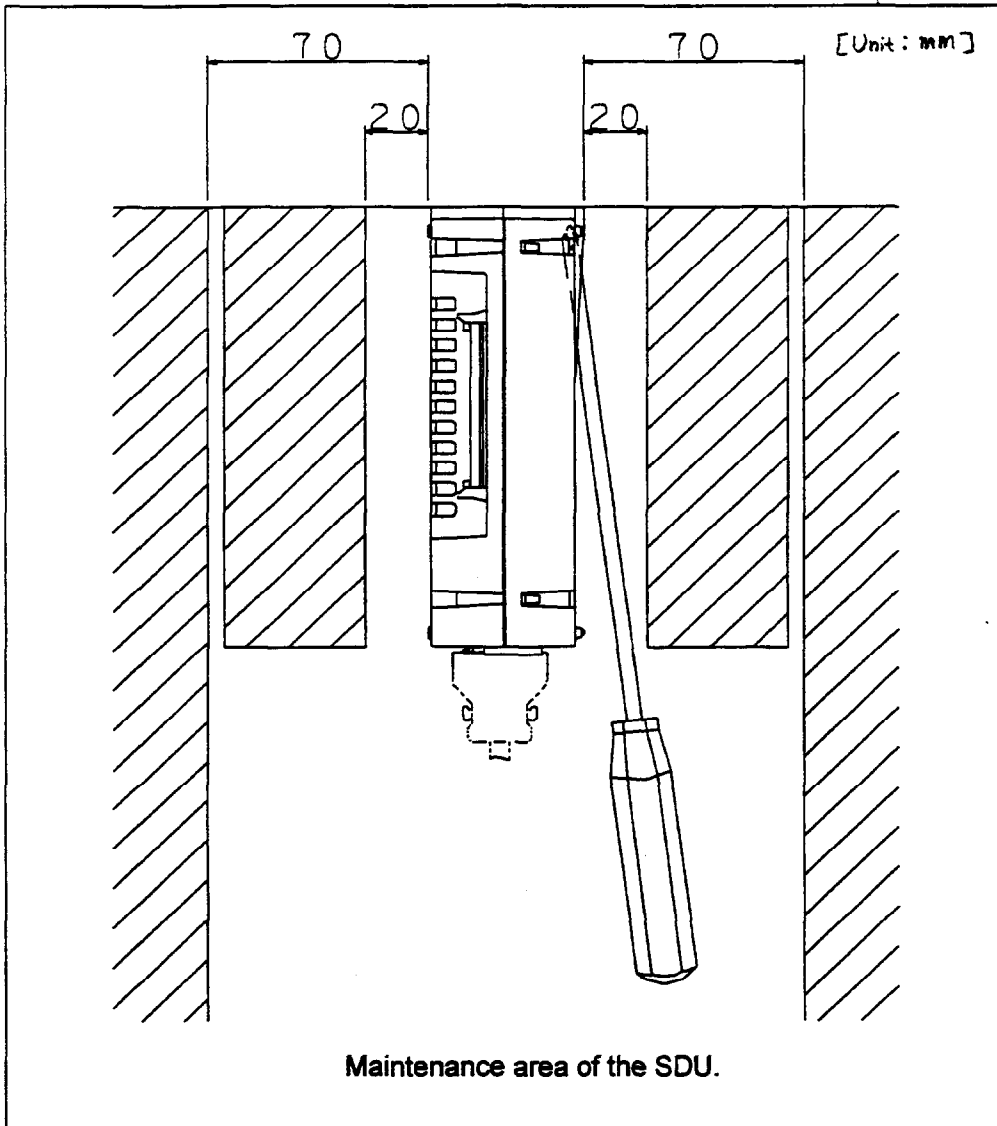

				TITLE	
				DRAM. NO.	CUST.
				A-73402E	
EDIT.	DATE	DESIG.	DESCRIPTION	FANUC LTD	SHEET 016/16

